



# INSTALLATION GUIDE

## Delta 800 Foul Packaged Pumping Station



[www.deltamembranes.com](http://www.deltamembranes.com)

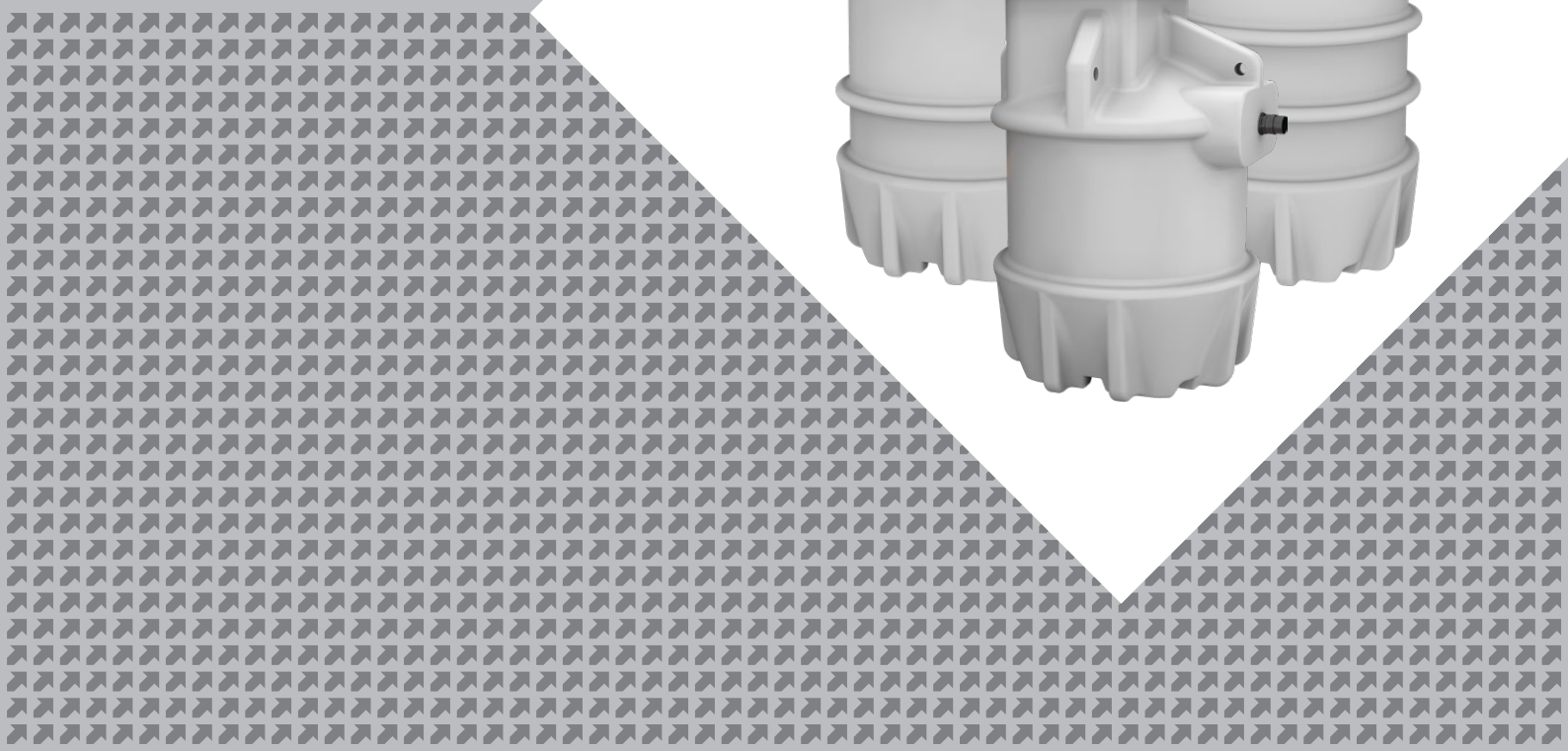

**THIS MANUAL SHOULD BE KEPT WITH  
THE PUMP STATION OR THE HOMEOWNER**

# Contents

1.	Delta 800 Foul Series overview .....	1
1.1	Delta 800 Foul Series overview .....	1
1.2	Example installation (single pump).....	1
1.3	Parts included .....	2
1.4	Optional extras.....	2
1.5	Pump specifications .....	2
1.6	Chamber specifications .....	3
2.	Discharge pipework and fittings .....	5
2.1	Discharge pipework and fittings.....	5
2.2	Spare parts for single pump versions.....	6
2.3	Spare parts for dual pump versions.....	7
3.	Chamber depth limits .....	8
4.	Installation guidelines.....	9
4.1	Installation guidelines .....	9
4.2	Pump station location .....	9
4.3	Installation within a reinforced concrete sump.....	9
4.4	Cable duct guidance.....	10
4.5	Vent duct guidance.....	11
4.6	Installation procedure .....	11
5.	Lifting guide .....	13
6.	Float configuration (dual pump only).....	14
7.	Control panel operation (dual pump only) .....	15
8.	Control panel wiring diagram (dual pump only) .....	16
9.	Wiring diagrams.....	17
9.1	Single pump versions with Delta HLA .....	17
9.2	Single pump versions with Delta Battery Backup Foul V3.....	18
9.3	Dual pump versions .....	19
10.	Maintenance .....	20
11.	Health and safety .....	20
12.	Warranty .....	21
13.	Troubleshooting .....	22
14.	Ancillaries.....	23
15.	Commissioning details.....	25

# 1. Delta 800 Foul Series overview

## 1.1 Delta 800 Foul Series overview

The robust and reliable Delta 800 Foul Series of packaged pumping stations has been specifically designed to collect foul and/or grey water from basements, below ground structures and ground floor extensions or where foul water cannot be drained by gravity. For kitchen applications we recommend fitting a grease trap prior to the pump station installation.

The Delta 800 Foul Series can accept waste from an extension, outbuilding, basement or similar, where the structure also has another method of removing foul water. Please contact our Technical Department if you require a foul water packaged pumping station to serve the whole property.

The Delta 800 Foul Series is not suitable for collecting ground water from a cavity drained membrane system.

Delta 800 Foul Series systems include: a polyethylene chamber, one or two Delta Foul V3 submersible pumps, pump pedestal(s) with guide rail(s), 110 mm inlet, 110 mm

cable duct, 110 mm vent, 2" discharge and control panel (dual pump systems).

The pump station has been specifically designed for below ground applications. The chamber is manufactured from tank-grade polyethylene and as such is extremely robust.

To prevent movement, the chamber must be installed within a waterproof reinforced concrete sump and backfilled with concrete.

An access cover is not supplied, as these are generally site specific and installed in the final finish. The chamber will accept a standard 600 mm x 450 mm cover and frame. It should be double-sealed to prevent odours.

Inlets can easily be drilled and sealed on site, making this product straightforward to install.

Delta Dual 800 Series package pumping stations are available in depths of 1250 mm, 1500 mm, 1750 mm and 2000 mm.

## 1.2 Example installation (single pump)

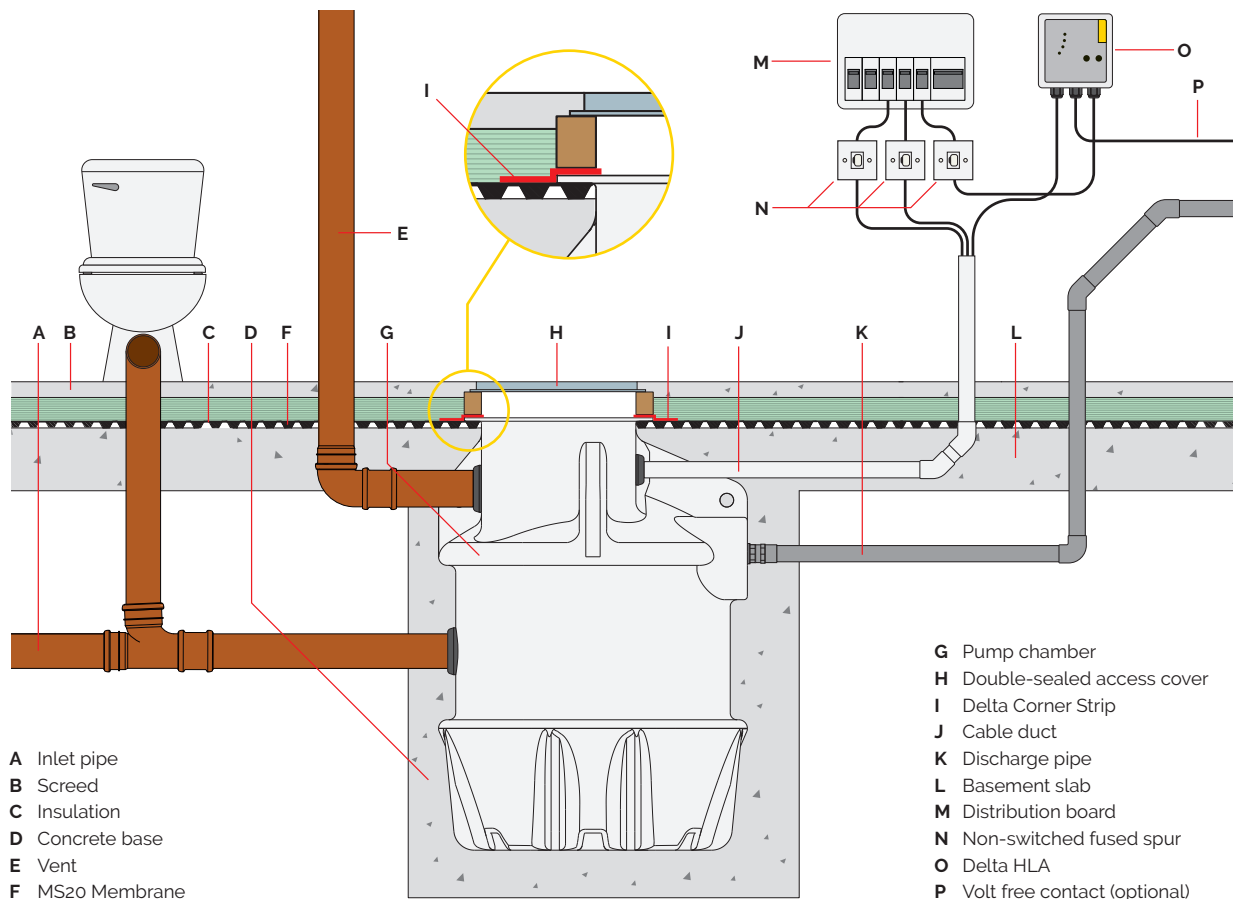

*For illustration purposes only.*

### 1.3 Parts included

- Chamber – 900 mm diameter by 1250/1500/1750/2000 mm deep
- 2" internal pipework and fittings
- 1 or 2 Delta Foul V3 submersible pumps
- 2" plain/threaded female socket for solvent weld to High Pressure PVC (Class E).
- Control panel, 3 sump floats (dual pump versions only)
- Pump pedestal(s)
- Guide rail(s), lifting chain(s) and shackles

### 1.4 Optional extras

- Delta HLA high level alarm (DMS 190) and Delta Sump Float Kit (single pump version only)
- Delta Battery Backup Foul V3 (DMS 029) (single pump version only)
- 2" discharge pipework and various fittings
- Additional inlets

### 1.5 Pump specifications

Pump specification		Foul V3
Impellor type		Vortex
Power	P <sub>1</sub> (kW)	1.25
	P <sub>2</sub> (kW)	0.75
Rated current (A)		6.0
Power phase		Single
Non-switched fused spur rating (A)		13
RCBO rating, Type C (A)		10
Free passage (mm)		45
Cable length (m)		10
Max. temperature continuous (°C)		40
Weight (kg)		23



*Delta Foul V3 (Automatic)  
for single pump models*

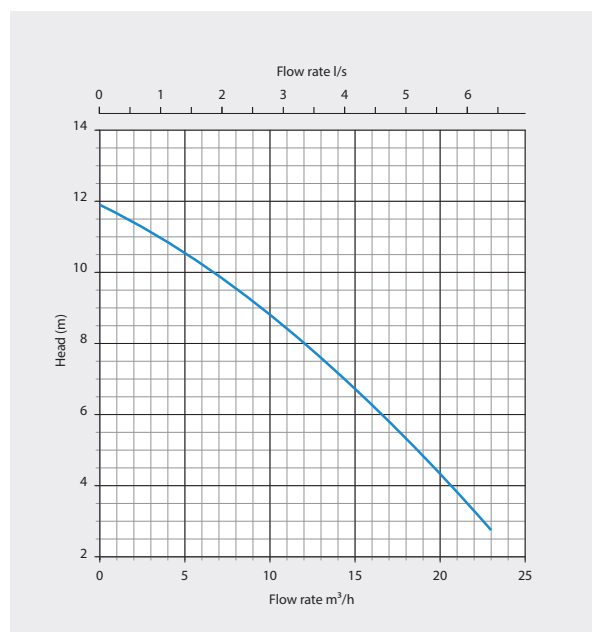

*Delta Foul V3 (Manual)  
for dual pump models*

1. Delta 800 Foul Series overview

1.6 Chamber specifications

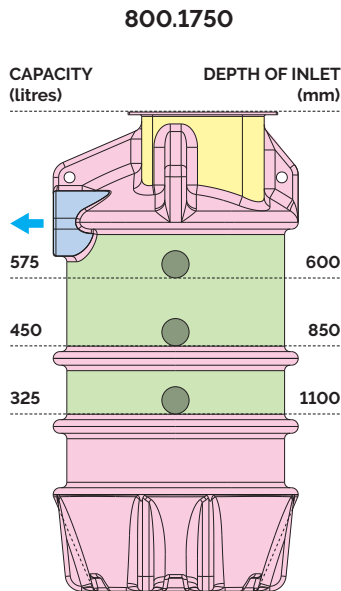
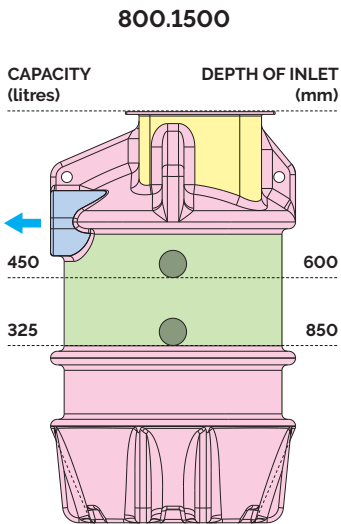
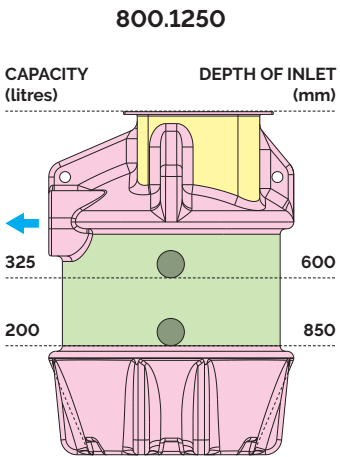
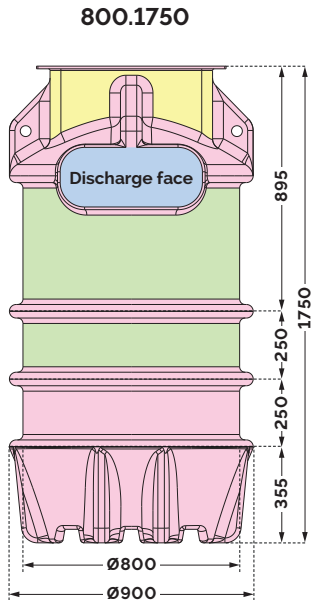
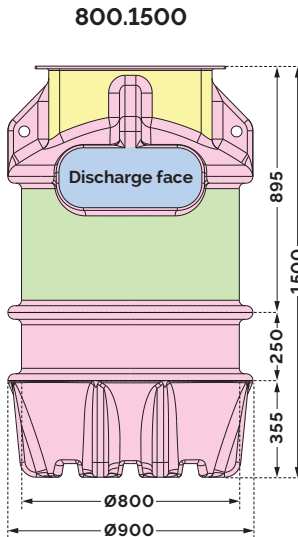
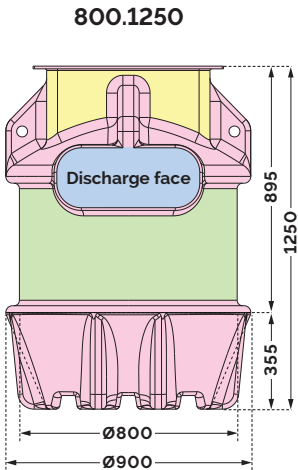

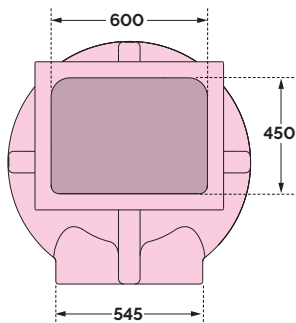
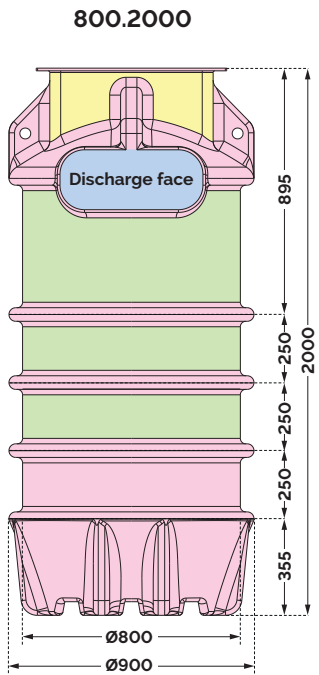

**Positioning connections**

Discharge only
Inlet location allowed
Cable ducts and vents only
No drilling allowed

All dimensions are in millimetres (mm). All capacities are in litres (l).

All inlet depths shown are to the invert level (bottom of pipe).

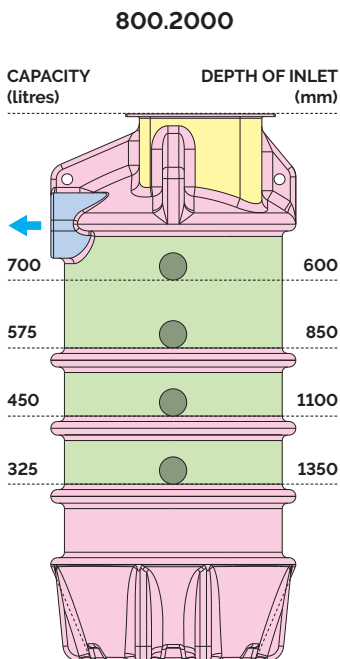

Chamber specification	
Chamber material	Tank-grade polyethylene
Inspection cover	Not supplied
Clear opening to chamber (mm)	600 x 450
Inlet (mm)	110
Cable duct (mm)	50 (single pump systems) 110 (dual pump systems)
Vent (mm)	110
External discharge connection	2" high pressure PVC Class E
Internal pipework manifold	2" high pressure PVC Class E

# 2. Discharge pipework and fittings

## 2.1 Discharge pipework and fittings

A selection of discharge pipework and fittings are available for the Delta Dual 800 Groundwater series.

Should you require to place an order for any of these items, please complete the form below, scan and email to pumps@deltamembranes.com to allow us to process your order.

Product	DMS Code	Qty req.
2" pressure pipe PVC Class E (2 m)	DMS E120	<input type="text"/>
90 degree elbow PL/PL, 2"	DMS E121	<input type="text"/>
45 degree elbow PL/PL, 2"	DMS E122	<input type="text"/>
Coupling (socket) PL/PL, 2"	DMS E123	<input type="text"/>
Coupling (socket) PL/TH, 2"	DMS E127	<input type="text"/>
Coupling (socket) TH/TH, 2"	DMS E131	<input type="text"/>
Male threaded adaptor (male iron), 2"	DMS E124	<input type="text"/>
50 mm male iron, low pressure	DMS E132	<input type="text"/>
Saddle clamp, 110 mm x 2" BSP female thread)	DMS E133	<input type="text"/>
2" pipe clip, PP, black	DMS E202	<input type="text"/>
Solvent cement, WDF-05, 250 ml	DMS E175	<input type="text"/>
PVC cleaning fluid, 500 ml, tin	DMS E176	<input type="text"/>
PTFE tape, roll	DMS E177	<input type="text"/>

Name:	
Company name:	
Delivery/site address:	
Email:	
Telephone number:	Mobile Number:

Signature:	Date:
------------	-------

**Please scan this order form and email to pumps@deltamembranes.com**



## 2.2 Spare parts for single pump versions

Part	Description	DMS Code
A	Delta Foul V3 (Automatic)	DMS 120
B	Barrel nipple PL/TH, 2"	DMS E128
C	90° elbow, 2"	DMS E121
D	High pressure PVC pipe (Class E), 2"	DMS E120
E	Socket union, 2" c/w 'O' ring	DMS E126
F	Brass swing check valve, 2"	DMS E193
G	Brass gate valve, 2"	DMS E188
H	Male threaded adaptor, 2"	DMS E124
I	Tank connector, 2"	DMS E130
J	Coupling PL/TH, 2"	DMS E127

Part	Description	DMS Code
K	Rubber wall seal, 50 mm (cable duct, 50 mm inlets)	DMS E168
L	Rubber wall seal, 110 mm (vent duct, 110 mm inlets)	DMS E169
M	2-hole sump float bracket, steel	DMS E234
N	Guide rail top bracket	-
O	Unistrut kit c/w bracket	-
P	Galvanised steel shackle, 8 mm	-
Q	Guide rail tube, galvanised steel, 25 mm	-
R	Galvanised steel lifting chain	-
S	Pedestal for Foul V3 Submersible Pump	DMS 163

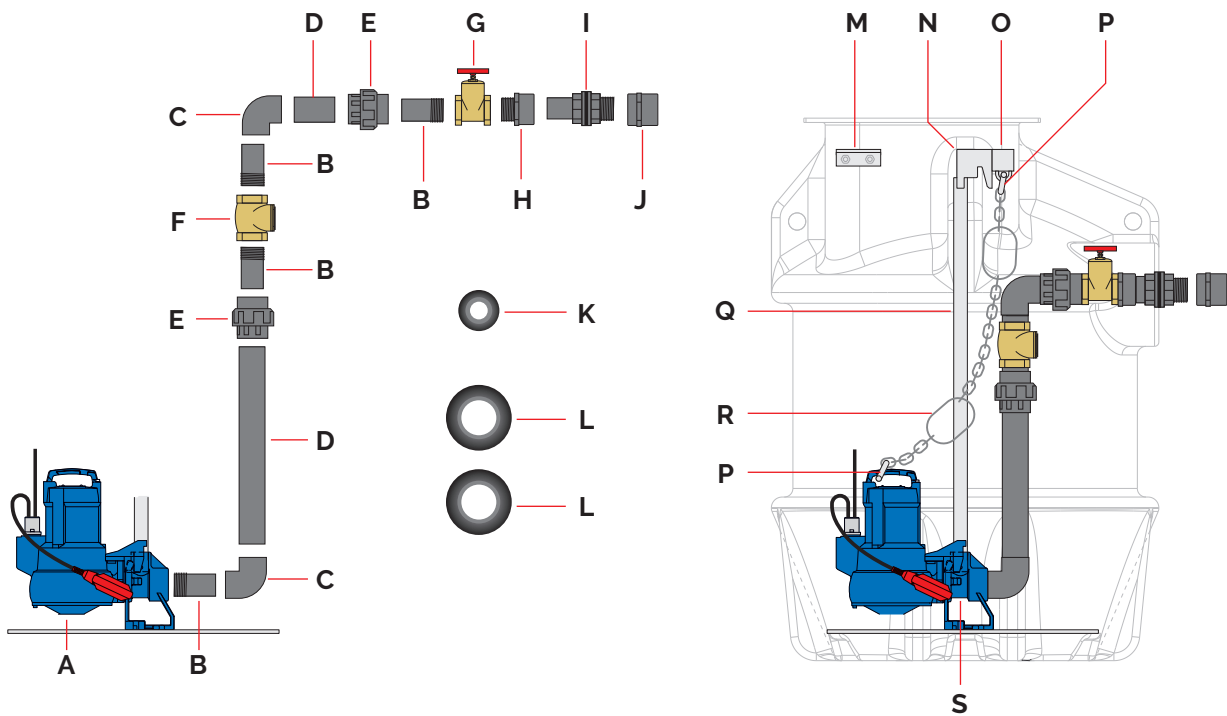

## 2. Discharge pipework and fittings

### 2.3 Spare parts for dual pump versions

Part	Description	DMS Code
A	Delta Foul V3 (Manual)	DMS E029
B	Barrel nipple PL/TH, 2"	DMS E128
C	90° elbow, 2"	DMS E121
D	High pressure PVC pipe (Class E), 2"	DMS E120
E	Socket union, 2" c/w 'O' ring	DMS E126
F	Brass swing check valve, 2"	DMS E193
G	Tee-piece PL/PL, 2"	DMS E125
H	Brass gate valve, 2"	DMS E188
I	Male threaded adaptor, 2"	DMS E124
J	Tank connector, 2"	DMS E130
K	Coupling PL/TH, 2"	DMS E127
L	Dual pump control panel	DMS E216 plastic / E217 metal

Part	Description	DMS Code
M	Rubber wall seal, 110 mm (110 mm inlets, cable duct, vent duct)	DMS E169
N	2-hole sump float bracket, steel	DMS E234
O	20 mm cable gland	DMS E211
P	Guide rail top bracket	-
Q	Unistrut kit c/w bracket	-
R	Galvanised steel shackle, 8 mm	-
S	Galvanised steel lifting chain	-
T	Guide rail tube, galvanised steel, 25 mm	-
U	Counterweight	DMS E215
V	Sump float switch with 10 m cable	DMS E158
S	Pedestal for Foul V3 Submersible Pump	DMS 163

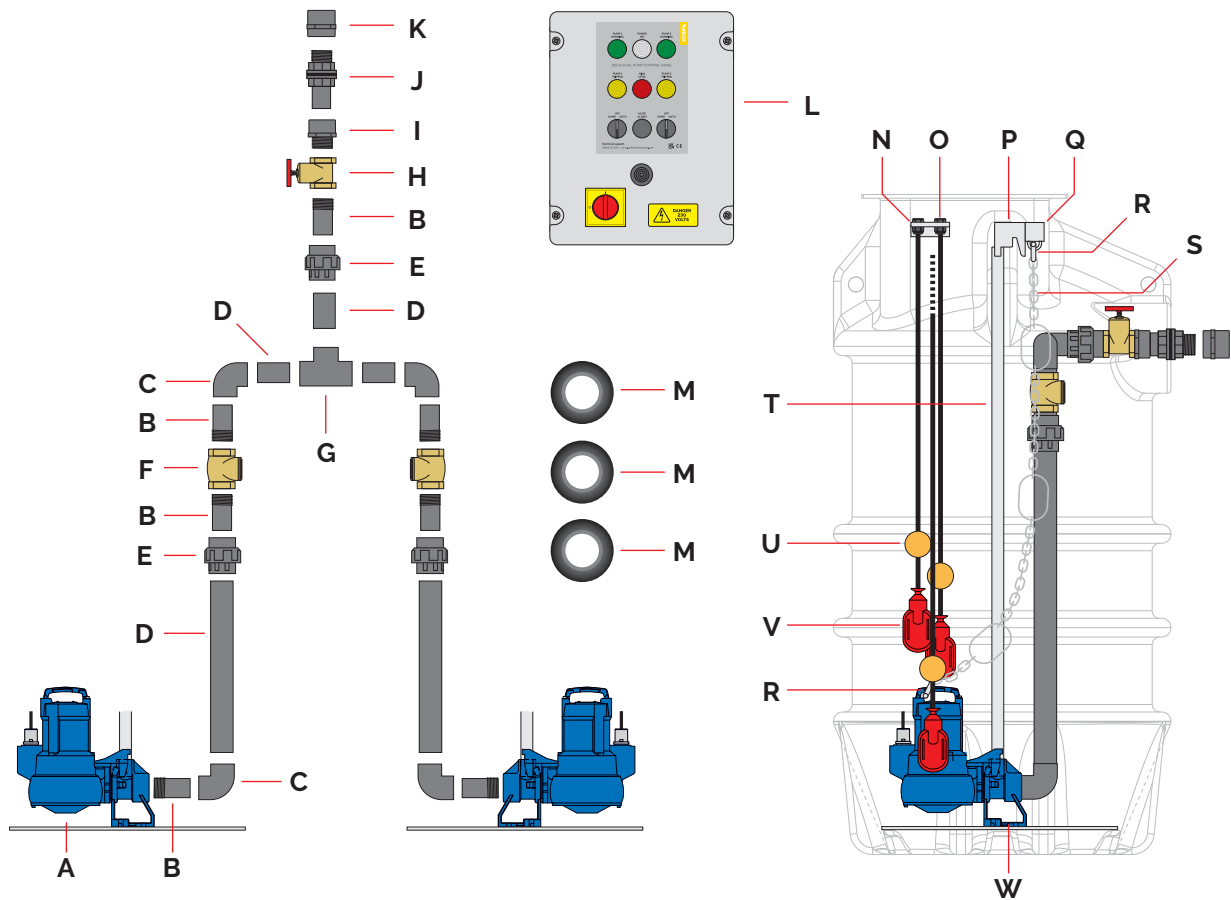

### 3. Chamber depth limits

The chamber must be installed less than 300 mm below the finished floor level (FFL) so that it can be serviced safely in accordance with the Construction (Design and Management) Regulations 2015 (CDM).

If the inlet inverts to not allow installation within this depth limit, please discuss chamber options with us on 01992 523 523 between 8am and 5pm, Monday to Friday or by email at [info@deltamembranes.com](mailto:info@deltamembranes.com) before proceeding.

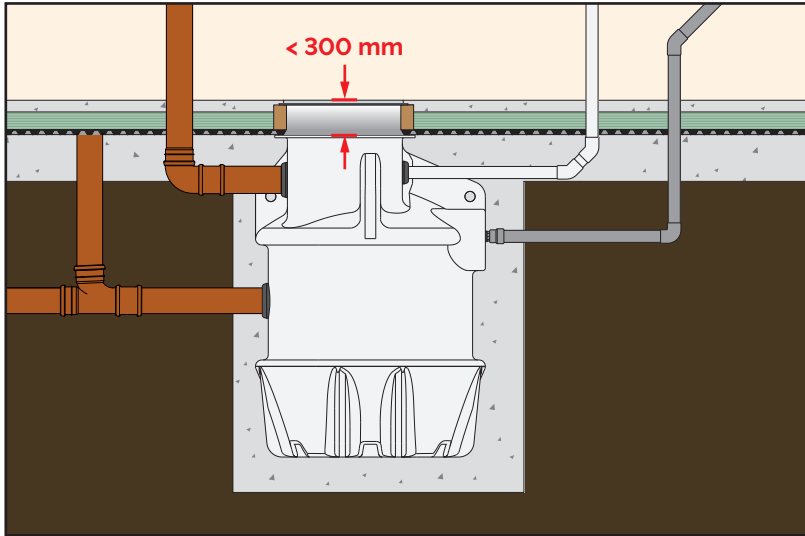

#### Less than 300 mm below FFL

The chamber must be installed no greater than 300 mm below FFL.

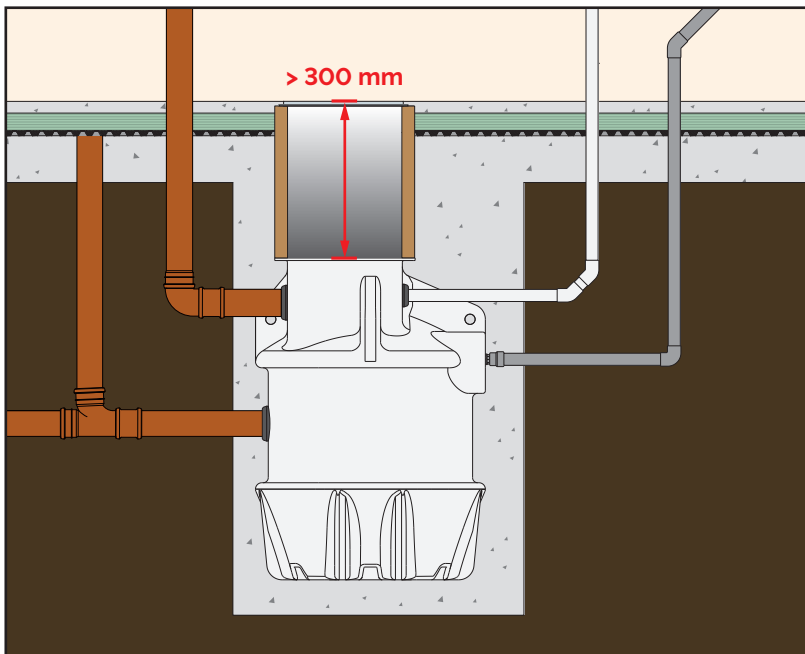

#### More than 300 mm below FFL

The chamber must not be installed at a depth below FFL greater than 300 mm.

It cannot be serviced safely in accordance with The Construction (Design and Management) Regulations 2015.



# 4. Installation guidelines

## 4.1 Installation guidelines

This guide is an illustration of installation guidelines which should be followed for proper installation of the Delta 800 Foul Packaged Pumping Stations, including housing. It is important to note these instructions are for guidance only and it is the installer's responsibility to satisfy themselves that the installation procedure is in accordance with the prevailing ground conditions and good build practice, to eliminate any potential damage to the pump station chamber either during or after installation. The installer should also satisfy themselves that the system can be installed in conjunction with these guidelines, prior to work commencing.

Please read these instructions in full before beginning the installation. If you are unsure on any point then contact Delta Membranes on 01992 523 523 between 8am and 5pm, Monday to Friday or by email at [info@deltamembranes.com](mailto:info@deltamembranes.com) before proceeding.

## 4.2 Pump station location

Delta 800 Foul Packaged Pumping Stations require routine maintenance. It is important that careful consideration is taken to position the chamber in a location which will allow for permanent access.

## 4.3 Installation within a reinforced concrete sump



**A structural and waterproofing engineer must be consulted when designing the waterproof reinforced concrete sump and backfill to ensure that it can withstand the anticipated pressures, and that they are not transferred onto the chamber.**

The chamber is manufactured from tank-grade polyethylene and is extremely robust. However, as with all pre-formed chamber they are susceptible to floatation and hydrostatic pressures exerted in high water table conditions.

To ensure these forces are not transferred onto the chamber, the chamber must be installed within a waterproof reinforced concrete (RC) sump.

Furthermore, when constructing the waterproof reinforced concrete sump, adequate space must be made for connections to the chamber e.g. inlets, discharge, cable and vent ducts. Consideration must also be made to the depth and orientation of all connections to ensure that they line up with the chamber.

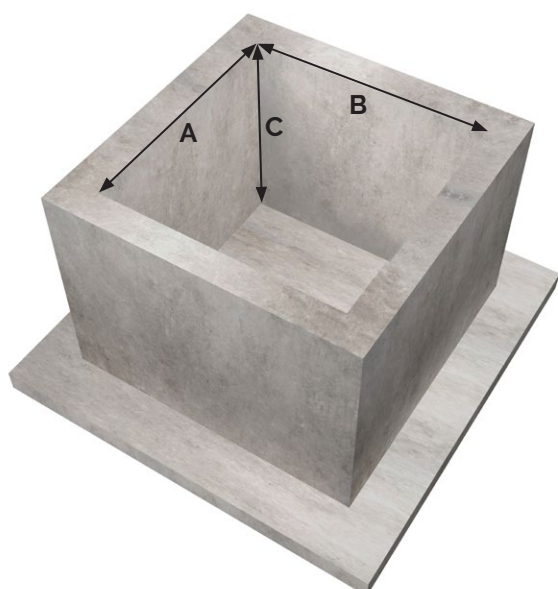

*Recommended RC sump dimensions*

Chamber	A (mm)	B (mm)	C (mm)
800.1250	1300	1300	1255
800.1500	1300	1300	1505
800.1750	1300	1300	1755
800.2000	1300	1300	2005

## 4.4 Cable duct guidance



It is vital to pull a draw cord through the cable duct as it is being constructed so that pump and float cables can be pulled through during installation. Ensure the cord's loose end cannot slip back into the duct.

### 4.4.1 CABLE DUCTS FOR DUAL PUMP SYSTEMS

The cable duct for dual pump systems should be 110 mm diameter waste pipe. A 110 mm rubber wall seal is supplied to connect the cable duct to the chamber. The cable duct can be positioned on any flat face of the chamber neck. Please refer to Section 1.6.

### 4.4.1 CABLE DUCTS FOR SINGLE PUMP SYSTEMS

The cable duct for the single pump systems should be 50 mm diameter. This can be low pressure ABS waste pipe or high pressure PVC. A 50 mm rubber wall seal is supplied to connect the cable duct to the chamber. The cable duct can be positioned on any flat face of the chamber neck. Please refer to Section 1.6.

To allow cables to be easily pulled through the 50 mm cable duct use sweeping corners instead of tight 90 degree elbows. These can be created by using two 45 degree elbows.

### 4.4.2 CABLE EXTENSIONS

If cable extensions are required for the pump power cables or the float cable, a qualified electrical contractor must make all electrical connections. Suitable cable extension kits are available to order. Please contact Delta Membranes on 01992 523 523 between 8am and 5pm, Monday to Friday or by email at [info@deltamembranes.com](mailto:info@deltamembranes.com) for more information.

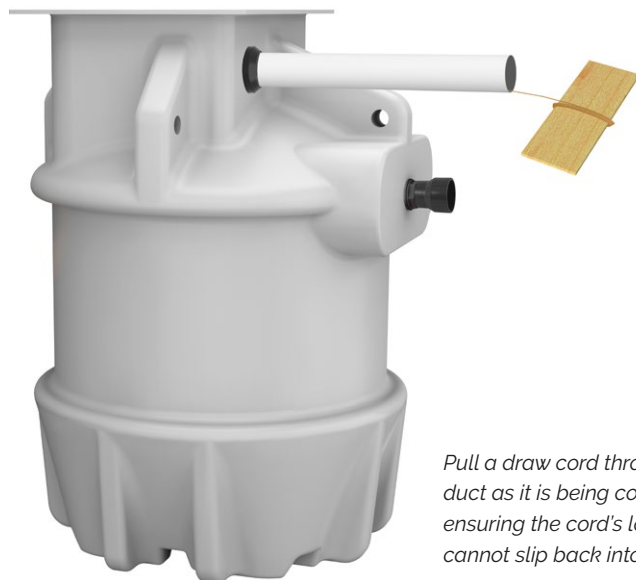

*Pull a draw cord through the cable duct as it is being constructed, ensuring the cord's loose end cannot slip back into the duct.*

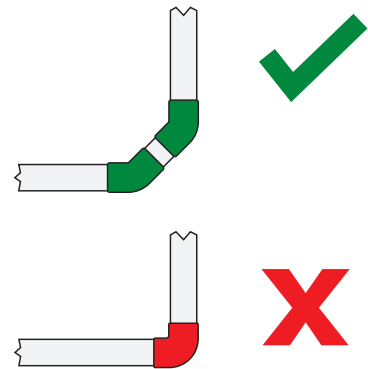

*For 50 mm cable ducts used on the single pump systems, swept bends allow the cables to be pulled through without snagging.*

## 4. Installation guidelines

### 4.5 Vent duct guidance

If the pumping station receives foul and/or grey water then a vent duct must be installed. This duct must be vented to atmosphere. An air-admittance (Durgo) valve must not be installed.

The vent duct's primary purpose is to equalise pressure within the chamber. It will also mitigate any odours from foul waste in base of the chamber.

The vent duct should be constructed of 110 mm waste pipe. A 110 mm rubber wall seal is supplied to connect the vent duct to the chamber. The vent duct can be positioned on any suitable flat face of the chamber neck. Please refer to Section 1.6.

When installing in conjunction with a cavity membrane system, care must be taken to prevent foul odours from being transmitted to the cavity. Tuck the cavity membrane under the chamber's flange then seal with Delta Corner Strip (DMS 020).

### 4.6 Installation procedure

Please read these instructions in full, prior to commencement of the installation. If you are unsure on any point then contact Delta Membranes on 01992 523 523 between 8am and 5pm, Monday to Friday or by email at [info@deltamembranes.com](mailto:info@deltamembranes.com) before proceeding.

1. Select a suitable location for the pumping station. Where possible, installation of a pumping station in a roadway should be avoided due to the need for periodic maintenance of the pumps contained therein. If the location is adjacent to a roadway, the installation method should take into account the imposed loads likely to be transmitted to the chamber by traffic etc.
2. Construct a suitable waterproof reinforced concrete (RC) sump (please refer to Section 4.3 for details).
3. Lift the chamber into the RC sump (please refer to Section 5) and position it such that all connections are correctly aligned. Mark all connections and remove the chamber from the RC sump.
4. Install the rubber seals into the chamber wall for the cable duct (50 mm for single pump systems, 110 mm for dual pump systems), 110 mm vent duct, and the inlet(s). The size and number of inlets is project dependent (one 110 mm rubber wall seal is supplied as standard for inlets).

All connections should be aligned square to the chamber enabling the seals to remain watertight .



**Ensure a draw cord is pulled through the cable duct as the cable duct is built. Please refer to Section 4.4.**

5. Lay a WET mass concrete into the base of the RC sump to a thickness of 100 mm.
6. Lift the chamber into the excavation (please refer to Section 5) and carefully position it onto the WET mass concrete base ensuring that no loose debris is inadvertently knocked onto the base under the chamber during this procedure.  
  
Manipulate the chamber so that it sits on the base of the RC sump then position it so that the inlet(s), cable duct, vent and discharge connections are correctly aligned.
7. Once the chamber is positioned, connect the cable duct, 110 mm vent duct and inlet pipework to the chamber (please use fittings supplied). The discharge pipework can then be connected. The discharge pipework should be able to withstand high pressure (PVC Class E or MDPE).
8. The vent duct should be vented to atmosphere; no air admittance (Durgo) valve to be used.
10. Whilst the concrete base is still WET, backfill the space between the chamber and the RC sump to the top of the chamber with WET mass concrete in a single pour. The concrete must be evenly poured around the chamber ensuring that no voids are left within the concrete.

During the backfilling process the chamber should be ballasted by steadily filling it with water. The difference in level between the concrete backfill and the water ballast should always be less than 300 mm.



**To prevent the chamber from floating up when the RC sump is backfilled, the chamber must be ballasted with water at the same rate as backfilling. The level difference between the water and backfill must not exceed 300 mm at any time.**

Care must be taken to ensure that any pipes (or other connections) are not damaged. During the concrete pour, ensure that the chamber is vertical (by using a spirit level across the chamber's opening). Additionally, ensure that the chamber remains at the correct depth level.

11. Allow time for the concrete to cure completely, then remove the ballast water.



**The ballast water inside the chamber should not be removed until the backfill has fully set.**

12. Fit the access cover (not supplied) onto the top of the access shaft so that it is flush with finished floor level.
13. In a roadway application, the chamber should be installed with the top of the access shaft 300 mm below the finished cover level ensuring that the slab is supported by consolidated backfill. A suitably rated access cover should be embedded into the reinforced cover slab (to be specified at time of order). It should not bear on undisturbed ground around the excavation nor directly onto the chamber, so that imposed loads are deflected away from the chamber. Design of the cover slab is the responsibility of the installer/structural engineer.
14. If the control panel is to be installed outside, it must be housed in a kiosk adjacent to the chamber. The kiosk should be fixed to a suitably sized concrete plinth complete with cable ducts for the cabling from the chamber and the incoming power supply. If the control panel is not to be sited adjacent to the chamber, please advise us at time of ordering so that we can discuss cabling requirements.
14. Once the chamber has been installed and the ballast water has been drained, it is extremely important that all sand, silt, rubble and general debris is removed from the chamber.



**Failure to remove sand, silt, rubble and all other debris from the chamber will invalidate the warranty on the pumps.**

15. Partly refill the chamber with clean water for testing the system upon commissioning, and so that the discharge pipe can be flushed through.
16. Install the pumps and float switches and draw their cables through the cable duct using the draw cord.
17. Mount the control panel at the desired location.
18. Provide a suitable electrical connection, this is to be isolated and adjacent to the now positioned control panel.
19. Make the final electrical connections as per the control panel wiring diagram (refer to Section 8). For single pump systems which use a Delta HLA high level alarm, please refer to the Delta HLA installation guide.



**A qualified electrician must carry out all electrical connections.**

20. Commission the pumping station. If you require a commissioning service please contact Delta Membranes on 01992 523 523 between 8am and 5pm, Monday to Friday or by email at [info@deltamembranes.com](mailto:info@deltamembranes.com).



**When commissioning the system check that all socket unions are fully tightened and not leaking. If a leak is detected, undo the socket union and check that its O-ring is seated correctly, then re-tighten. Do not overtighten as this can damage the fitting.**

# 5. Lifting guide



These instructions must be followed to prevent injury to operatives or damage to the product.

- Create a lifting plan, noting the following specifics, to prevent injury to operatives or damage to the product during the lifting process.
- Refer to the individual pallet / product's weight sticker and make sure the lifting equipment is suitable for this weight.
- Inspect all the chamber's lifting eyes.
- Do not use chains. The product must be lifted using a 4-hook lifting spreader beam with the correct length and breadth for the widths of the chamber's lifting eyes.
- Under no circumstances should the lifting equipment impinge on the clear opening flange. This will apply pressure to the flange and will damage the chamber.
- Adhere to all current legislative and training requirements.

If you require further advice contact Delta Membranes on 01992 523 523 between 8am and 5pm, Monday to Friday or by email at [info@deltamembranes.com](mailto:info@deltamembranes.com) before attempting to lift the product.

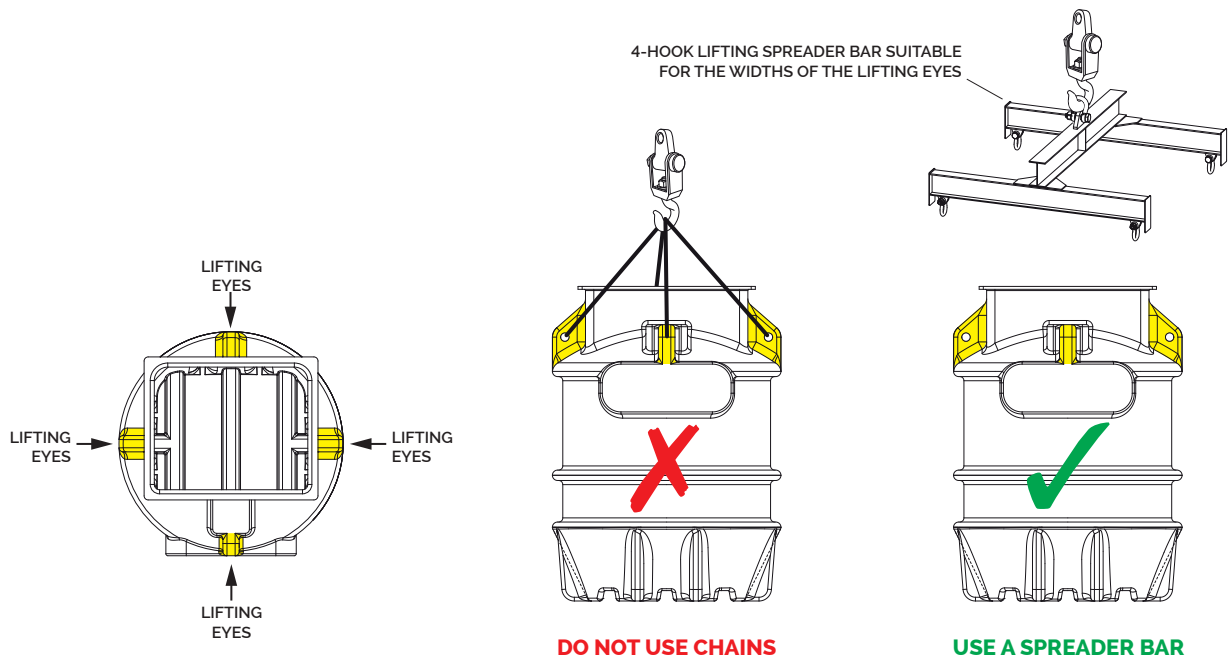



## 6. Float configuration (DUAL PUMP ONLY)

The Delta 800 Dual Foul V3 packaged pumping station's control panel is designed to operate with three sump float switches: Stop, Start and High Level / Duty Assist.

### STOP FLOAT

The Stop float controls the level at which the pumps turn off. It also needs to be in the On position for the pumps to start.

### START FLOAT

The Start float controls the level at which the duty pump will activate. The Start float and Stop float both need to be in the On position for the duty pump to start.

### HIGH LEVEL / DUTY ASSIST FLOAT

The High Level float will activate the alarm/beacon on the control panel should the level inside the tank continue to rise due to a pump failure or the volume of waste water exceeds the discharge capability of the pumps.

This float switch will also activate the standby pump should the duty pump fail or if the level inside the tank continues to rise even after the duty pump has activated.

### Positioning the floats and counterweights

- The Stop Float should be positioned approximately 100 mm above the intake of the pumps.
- The Start Float should be positioned at a level just above the top of the pumps.
- The High Level/ Duty Assist Float should be positioned approximately 150 mm above the Start Float.
- Counterweights should be positioned 70 mm – 100 mm above the top of the float. Fasten securely but do not over-tighten to prevent damage to the float cable.

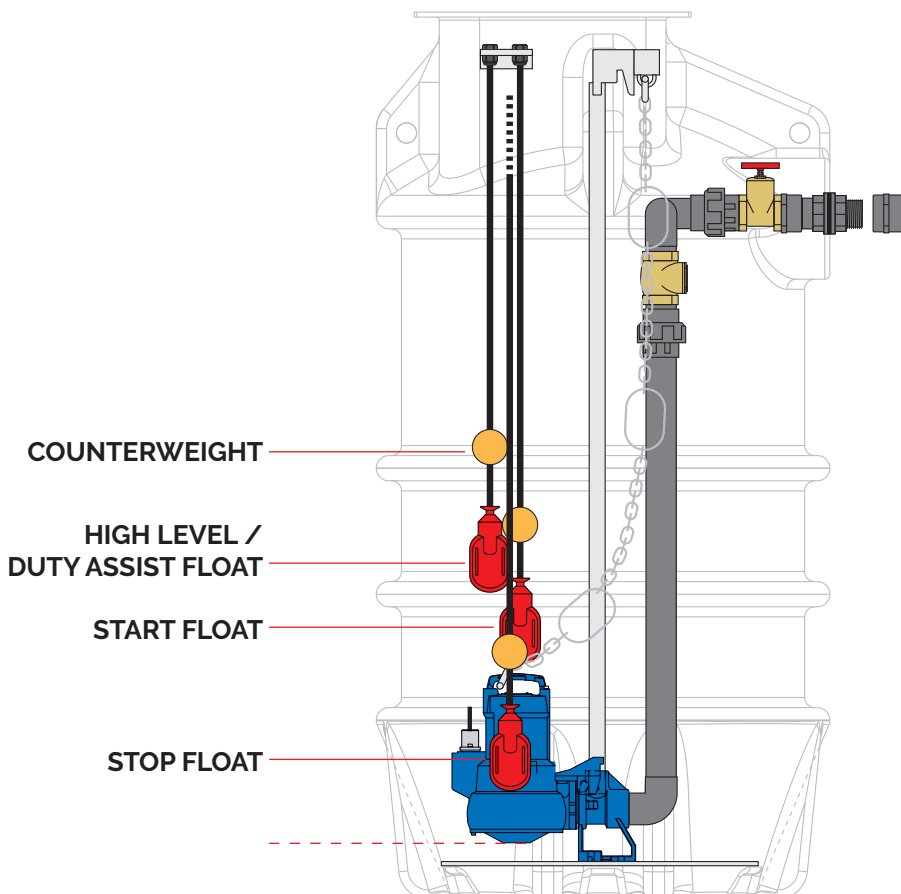

## 7. Control panel operation (DUAL PUMP ONLY)

- A. Pump 1 Running Indicator.** When lit this signifies that Pump 1 is in operation.
- B. Power Indicator.** When lit this signifies the control panel has power.
- C. Pump 2 Running Indicator.** When lit this signifies that Pump 2 is in operation.
- D. Pump 1 Tripped Indicator.** When lit this signifies that there is a problem with Pump 1, causing the overload relay within the panel to trip.
- E. High Level Indicator.** When lit this signifies that there is a high level condition within the chamber.
- F. Pump 2 Tripped Indicator.** When lit this signifies that there is a problem with Pump 2, causing the overload relay within the panel to trip.
- G. Pump 1 Control Switch.** This switch controls the operation of the Pump 1. It has three settings:
- HAND** This will run Pump 1 without the use of the float switches.
- OFF** This will remove all power to Pump 1 for maintenance and break downs to prevent any further damage to Pump 1.
- AUTO** This will run Pump 1 according to the float switches within the chamber. This is the setting for normal operation.
- H. Alarm Mute Button.** This button will silence the audio sounder should there be a high level condition within the chamber.
- G. Pump 2 Control Switch.** This switch controls the operation of the Pump 2. It has three settings:
- HAND** This will run Pump 2 without the use of the float switches.
- OFF** This will remove all power to Pump 2 for maintenance and break downs to prevent any further damage to Pump 2.
- AUTO** This will run Pump 2 according to the float switches within the chamber. This is the setting for normal operation.
- J. High Level Alarm.** This is the audio sounder that will activate if there is a high level condition within the chamber.
- K. Mains Isolator Switch.** This switch controls the main electrical supply to the unit.

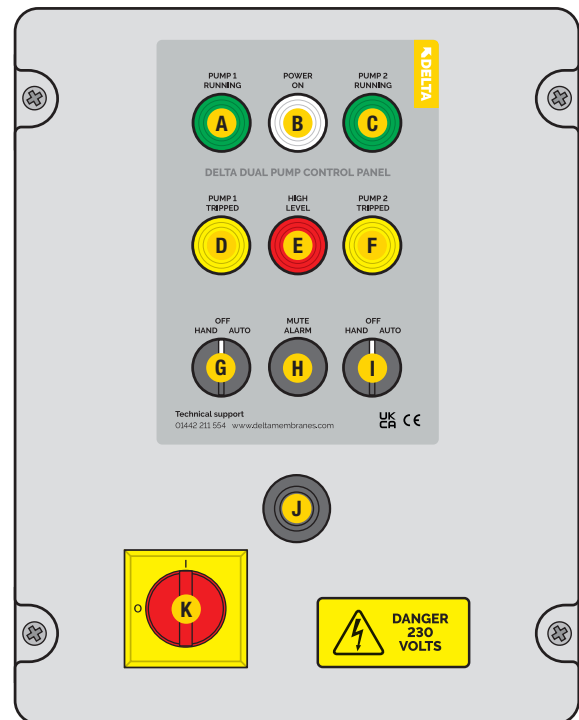

*Delta Dual Pump Control Panel*



### IMPORTANT INFORMATION

- Never leave a pump running on manual unattended, this can lead to the pump taking in air, which will cause an air lock within the pipework or may lead to permanent damage to the pump(s).
- Should a Pump Tripped Indicator become lit, it is advised that the Pump Control Switch be put into the OFF position to prevent any potential damage to the pump/s and contact your Pump Service Provider for further advice.

# 8. Control panel wiring diagram (DUAL PUMP ONLY)

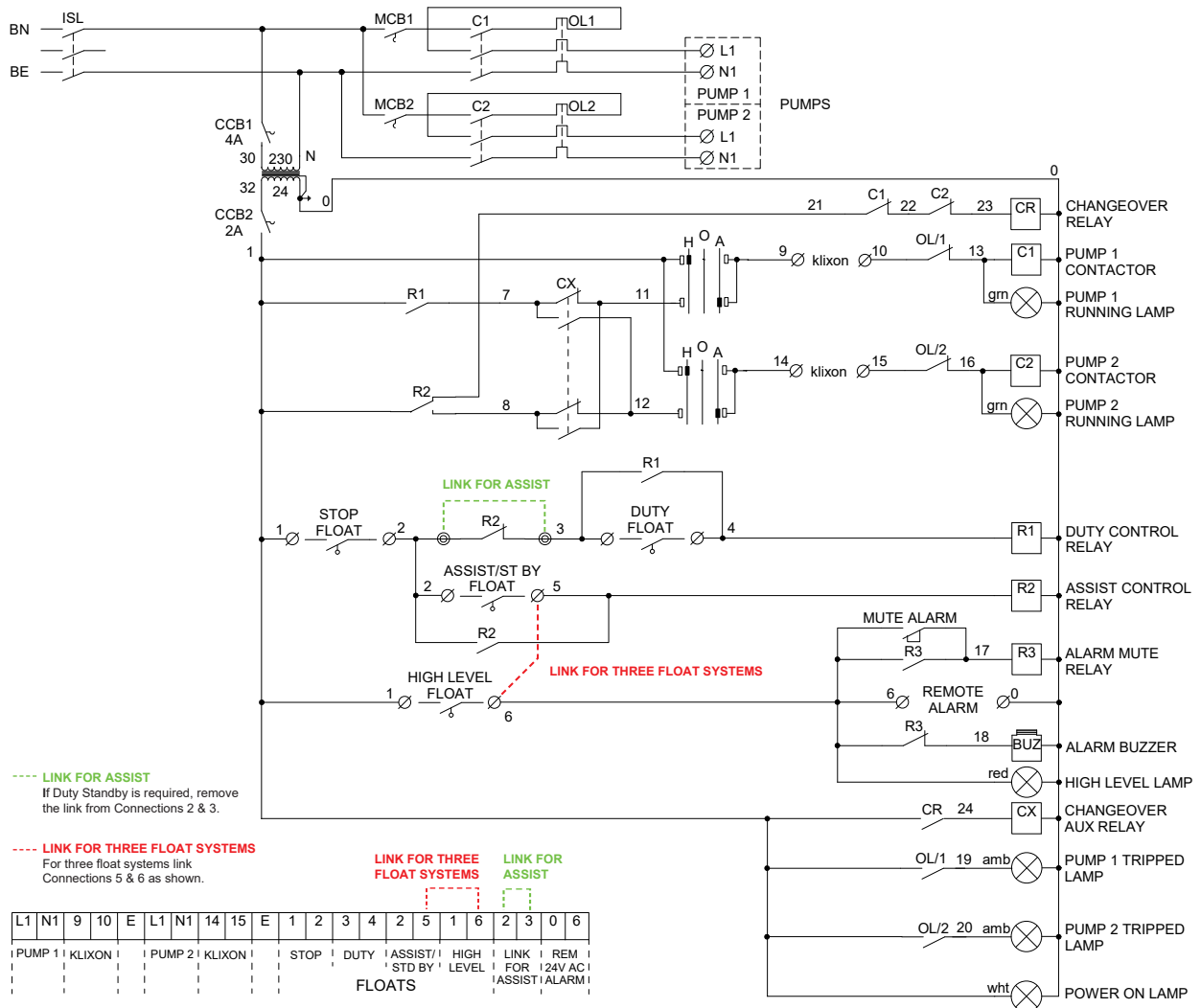

## Control panel specifications

### Delta Dual Pump Control Panel

Enclosure material	ABS
Ingress protection	IP54
Voltage	240 V
Volted contact	24 V (high level alarm)
Volt-free contact	No
Locking	4no screws
Safety	Door locking isolator
Start method	Direct online starter
Dimensions (W/H/D)	300 mm / 380 mm / 180 mm

## Legend

	Coil		Outgoing terminal
	Buzzer		Internal terminal
	Beacon		NO contact
	Lamp		NC contact
	Heater		NO timer
	Fuse		NC timer
	Float		Link

# 9. Wiring diagrams

## 9.1 Single pump versions with Delta HLA

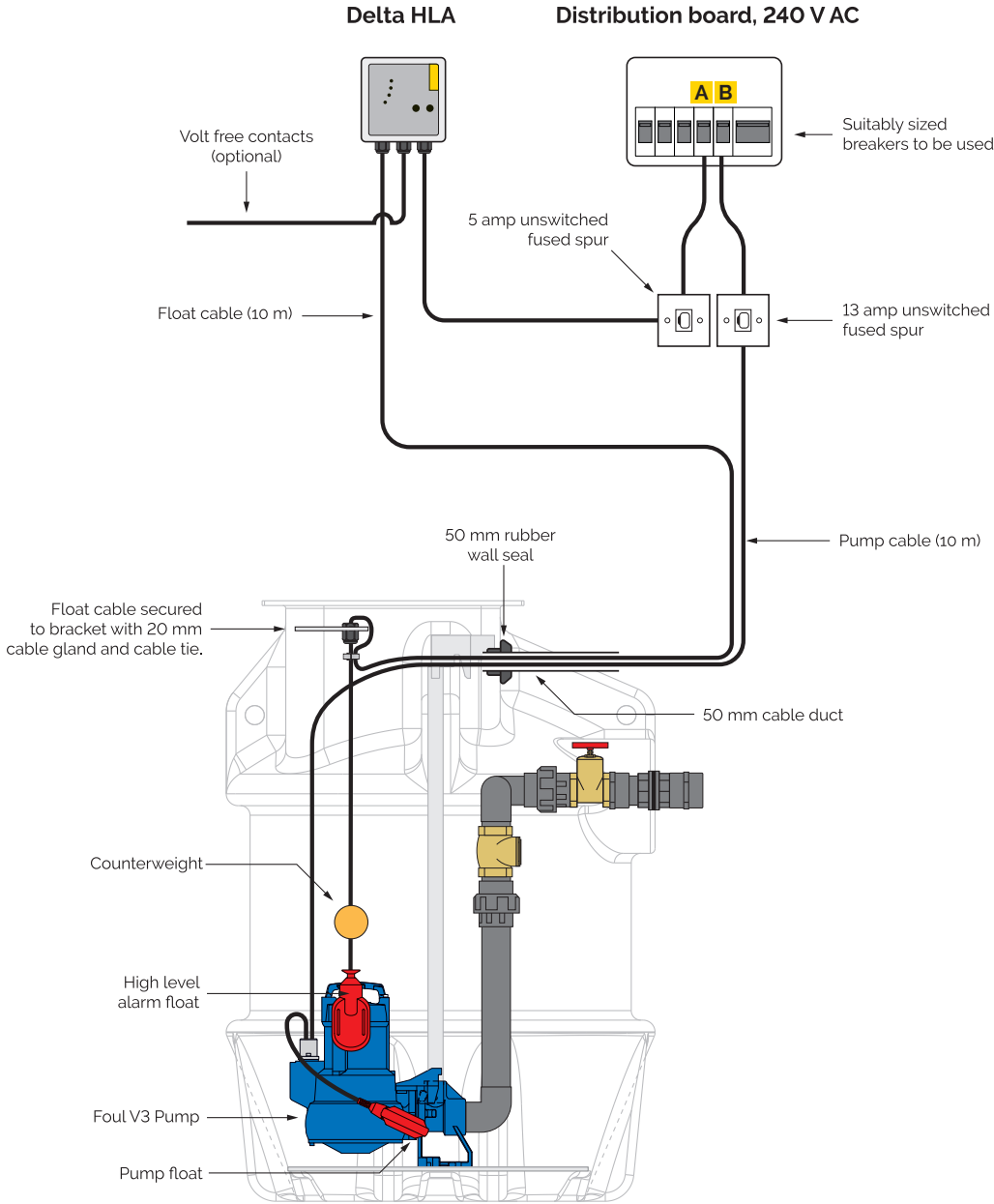

### BREAKER SPECIFICATION

Description	Device type	Rating
A Delta HLA	MCB	6 A
B Delta Foul V3 Pump	RCBO, Type C	10 A

9.2 Single pump versions with Delta Battery Backup Foul V3

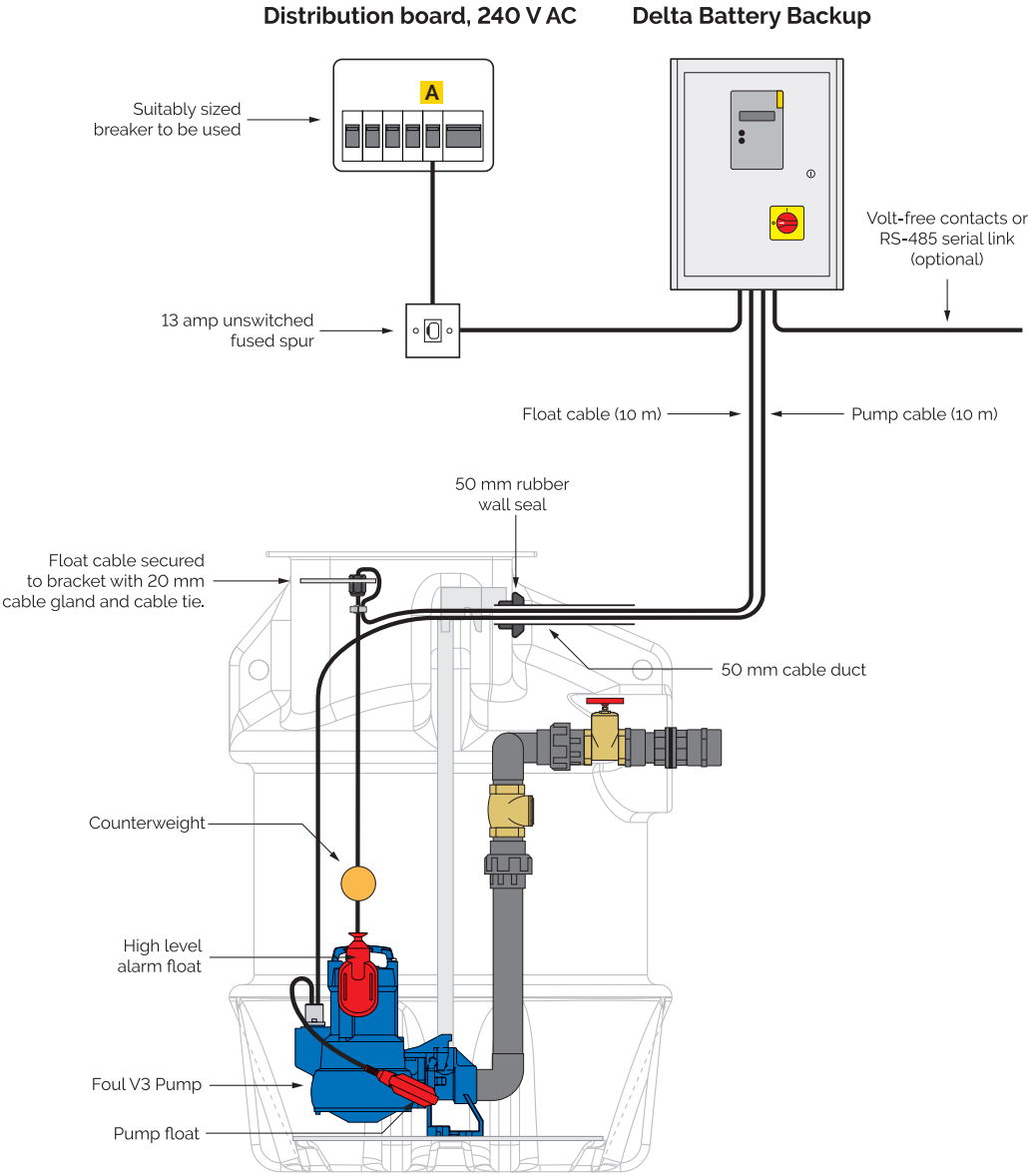

BREAKER SPECIFICATION

Description	Device type	Rating
A Delta Battery Backup	RCBO, Type C	10 A

9.3 Dual pump versions

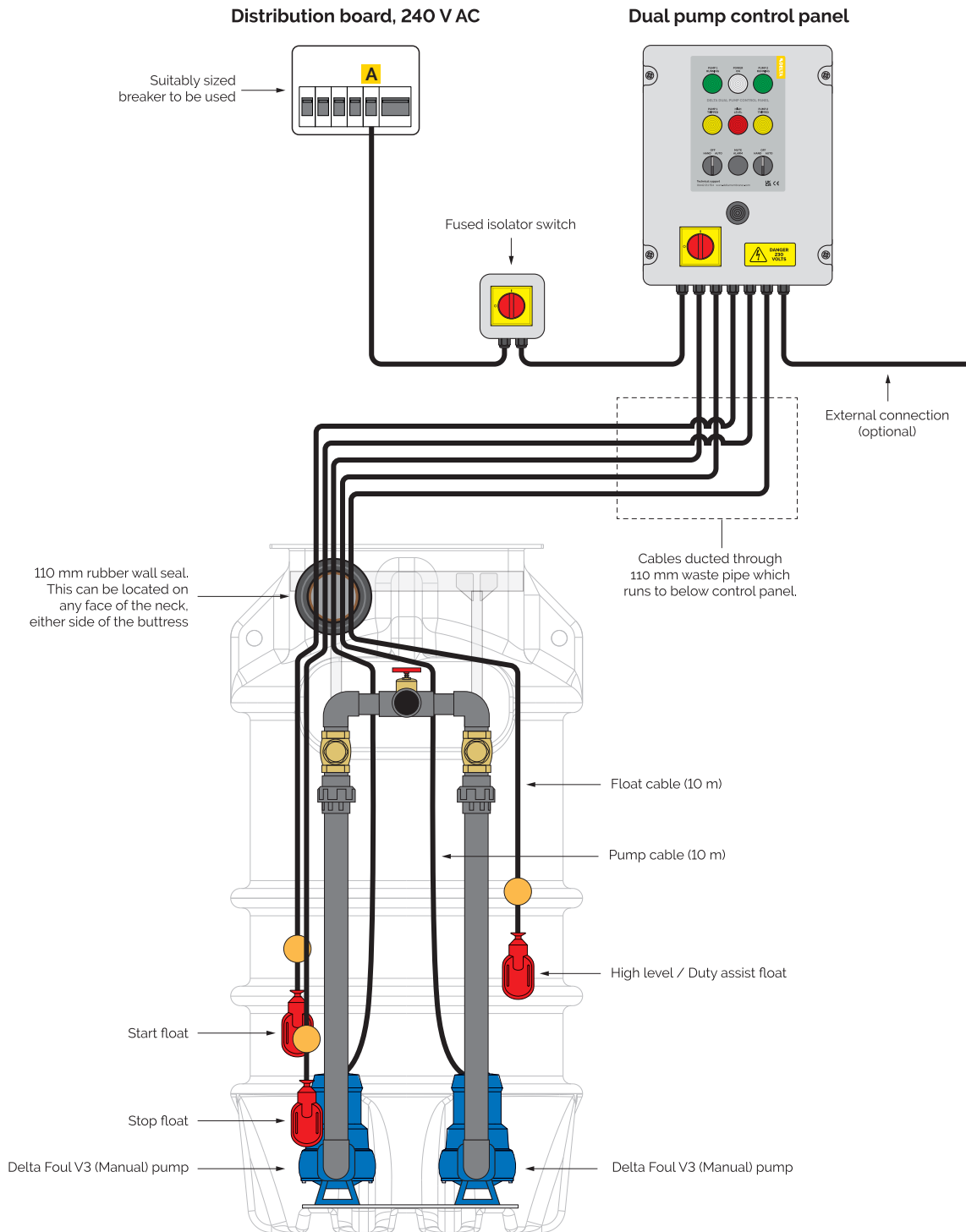

BREAKER SPECIFICATION

Description	Device type	Rating
A Delta Dual Pump Control Panel	RCBO, Type C	20 A

# 10. Maintenance

Sump pumps must be maintained. We recommend a qualified engineer examines and services equipment every year. Pumps running frequently due to higher water table, water drainage, or weather conditions should be examined more frequently, we recommend every 6 months. Sump pumps, being mechanical devices, may fail if not maintained which could lead to a flooded basement and costly repairs.

Regular servicing of sump pumps will increase efficiency and extend the life of the pump. All Delta pump systems should be maintained by one of our Delta Registered Pump Service Providers or installing contractor.

# 11. Health and safety

In order to minimise the risk of ill health or accidents when installing and/or servicing pump chambers, workers must be fully trained, competent and follow the health and safety guidelines below:

- Do not work without a risk assessment being in place.
- Work in accordance with the control measures identified in the risk assessment.
- All personnel must be vaccinated against diseases to which they may be exposed to, i.e. Tetanus, Polio, Hepatitis A&B, etc.
- At the time of writing, due to there being no vaccine against leptospirosis/Weil's disease, where rats may be present, ensure appropriate personal protective equipment (skin protection) is worn and ensure any cuts or abrasions are fully covered.
- There should be no eating or drinking during works and only afterwards following a change of clothing and washing.
- Ensure electrical power to the pump is turned off/isolated before carrying out installation or maintenance.
- A suitable first aid kit must be close to hand.

# 12. Warranty



## 12.1 Standard 12-month component warranty

The Delta 800 Foul Packaged Pumping Station is offered with a 12-month component warranty from the date of invoice. This does not include submersible pumps, which have a standard 24-month warranty (refer to Section 12.2).

Standard Delta Membrane Systems Limited conditions apply.

This warranty does not cover defects caused by incorrect installation, installation/installer error, abnormal working conditions, misuse, or neglect.

Any defects or malfunctions should be reported to Delta Membrane Systems Limited within 7 days of when the defect becomes apparent. All broken components should be returned to Delta Membrane Systems Limited at customer cost.

To make a Warranty Claim, please email [pumps@deltamembranes.com](mailto:pumps@deltamembranes.com). Forms are available from [www.deltamembranes.com](http://www.deltamembranes.com).

In no event shall Delta Membrane Systems Limited be liable for any consequential damage, penalties, loss, or expenses howsoever arising, out of or in connection with incorrect installations or misuse, including, without limitation, direct or indirect loss, consequential loss or damage, loss of profit or goodwill, loss arising from any errors or omissions in the pump chamber as a result of, incorrect installation, installation/installer error, abnormal working conditions, misuse, or neglect.

Delta Membrane Systems Limited shall not accept liability if the pumping system fails due to being incorrectly specified by any third parties not employed by Delta Membrane Systems Limited.

Delta Membrane Systems Limited shall not accept liability if the pump system fails due to discharge of inappropriate fluids/solids including, but not limited to, building debris or materials.

### 12.1.1 Warranty from date of commissioning

When the Delta 800 Foul Packaged Pumping Station is commissioned by a Delta Registered Pump Service Provider, the 12-month warranty period will begin at date of commissioning, subject to:

- all services and associated systems are ready to enable commissioning to take place;
- commissioning has been undertaken within 12 months from the date of invoice;
- the Delta 800 Foul Packaged Pumping Station is commissioned by a Delta Registered Pump Service Provider;
- the Delta Registered Pump Service Provider has logged Commissioning details of the Delta 800 Foul Packaged Pumping Station with Delta Membrane Systems Limited;
- the Delta 800 Foul Packaged Pumping Station is serviced by a Delta Registered Pump Service Provider with a minimum of a yearly Service (within 12 months from the date of commissioning/last service) depending on site specifications.

## 12.2 Standard 24-month pump warranty

Delta Foul V3 Pump(s) are offered with a standard 24-month warranty from date of invoice. In other respects the terms of the pump warranty are the same as the standard component warranty.

When a Delta Foul V3 Pump is commissioned, and then serviced regularly by a Delta Registered Pump Service Provider an extended 5-year pump warranty is offered (subject to the terms and conditions).

### 12.2.1 Five-year extended pump warranty from date of commissioning

Delta Membrane Systems Limited will offer a 5-year extended pump warranty on the Delta Foul V3 Pump(s) from date of commissioning, subject to:



- all services and associated systems are ready to enable commissioning to take place;
- the Delta Foul V3 Pump(s) is commissioned within 12 months from the date of invoice;
- the Delta Foul V3 Pump(s) is commissioned by a Delta Registered Pump Service Provider;
- the Delta Registered Pump Service Provider has logged Commissioning details of the Delta Foul V3 Pump(s) with Delta Membrane Systems Limited;
- all Delta Foul V3 Pump(s) registered under the extended 5-year warranty must be serviced by a Delta Registered Pump Service Provider with a minimum of a yearly Service (within 12 months from the date of commissioning/last service) depending on site specifications.



# 13. Troubleshooting

Please ensure the installation process has been completed thoroughly and all steps have been followed correctly.

Use the table below to assist with troubleshooting and if problems still occur, please contact Delta Membranes on 01992 523 523 between 8am and 5pm, Monday to Friday or by email at [info@deltamembranes.com](mailto:info@deltamembranes.com) for more information.

Fault	Cause
Water is leaking from discharge arms.	<p>If the leak is from a socket union, unscrew the union and check that its O-ring is seated correctly, then re-tighten. Do not overtighten as this can damage the fitting.</p> <p>PTFE tape not applied to male irons on discharge arms when attached to pumps.</p>
Pump isn't running.	<p>Pump doesn't have power – check wiring with reference to section 8.0 wiring diagram.</p> <p>Float isn't lifting – check float is free moving and not catching on chamber or other pump.</p> <p>Float is not turning on pump. Call Delta Technical.</p>
The pump is running but is not pumping water or is discharging very slowly (taking more than 40 seconds to empty the chamber).	<p>Gate valve isn't open or partially closed – turn valve anticlockwise to open.</p> <p>Pump is air locked – make sure there is a level of water to the top of the pumps, remove pump from union and lower back into water, lift float arm to activate pump before reconnecting to discharge arm.</p> <p>Discharge pipe is blocked – a drainage company is required.</p> <p>Pump impeller is jammed – turn off power and isolate pump, remove pump from chamber, unscrew pump base using Torx screwdriver and free impeller.</p>
<p> <b>WARNING!</b> Insure mains power and pump is isolated before taking pump apart and seek advice from a qualified electrician.</p>	
Pump is tripping.	<p>Pump is wired incorrectly or not on a separate supply – refer to section 6.0 wiring diagram.</p> <p>Pump impeller is jammed – turn off power and isolate pump, remove pump from chamber, unscrew pump base using Torx screwdriver and free impeller.</p>
<p> <b>WARNING!</b> Insure mains power and pump is isolated before taking pump apart and seek advice from a qualified electrician.</p>	
High level alarm is not functioning.	Refer to the high level alarm installation and operating instructions.

# 14. Ancillaries

**Pressure pipe, PVC Class E, 2 m**



1¼"    2"  
E100    E120

**Tank connector**



1¼"    2"  
E110    E130

**90° elbow PL/PL**



1¼"    2"  
E101    E121

**45° elbow PL/PL**



1¼"    2"  
E102    E122

**Tee-piece PL/PL**



1¼"    2"  
E105    E125

**Coupling (socket) PL/PL**



1¼"    2"  
E103    E123

**Socket union PL/PL**



1¼"    2"  
E106    E126

**Male threaded adaptor**



1¼"    2"  
E104    E124

**Coupling PL/TH**



1¼"    2"  
E107    E127

**Barrel nipple PL/TH**



1¼"    2"  
E108    E128

**Barrel nipple TH/TH**



1¼"    2"  
E109    E129

**Coupling TH/TH**



1¼"    2"  
E111    E133

**Reducer, PL/PL**



2" to 1½"  
E160

**Reducing bush, PL/TH**



1½" x 1¼"  
E161

**110 mm saddle clamp, reinf.**



1¼"      2"  
E113      E133

**Gate valve, brass**



1¼"      2"  
E187      E188

**Swing check valve, brass**



1¼"      2"  
E191      E193

**Non-return valve**



V3/4/6  
E195

**110 mm adaptor**



1¼"      2"  
E205      E206

**Rubber wall seal**



50 mm    110 mm    160 mm  
E168      E169      E170

**Solvent cement, WDF-05**



250 ml  
E175

**PVC cleaning fluid**



500 ml  
E176

**PTFE tape, roll**



12 mm x 12 m  
E177

# 15. Commissioning details

Property address	Commissioning engineers

Customer contact details	
Contact name	
Contact telephone	

Installation details	
Equipment installed	
Delta Registered Pump Service Provider	
Date of commissioning	
Commissioning engineer	
Signature of engineer	

## Servicing plans

Sump pumps must be maintained. We recommend a qualified engineer examines and services equipment every year. Pumps running frequently due to higher water table, water drainage, or weather conditions should be examined more frequently, we recommend every 6 months. Sump pumps, being mechanical devices, may fail if not maintained which could lead to a flooded basement and costly repairs. Regular servicing of sump pumps will increase efficiency and extend the life of the pump. All Delta Membrane pump systems can be maintained and serviced by our recommended service companies or installing contractor.

## Commissioning

All sump pumps require commissioning. Commissioning provides peace of mind, knowing that the system is installed correctly and in compliance with warranty conditions. All Delta Membrane pump systems can be commissioned by our recommended service companies or installing contractor.







Delta Membrane Systems Ltd, Delta House, Merlin Way, North Weald, Epping, Essex, CM16 6HR.

01992 523 523 [info@deltamembranes.com](mailto:info@deltamembranes.com) [www.deltamembranes.com](http://www.deltamembranes.com)

 [deltamembranes](https://www.facebook.com/deltamembranes)  [deltamembranes](https://twitter.com/deltamembranes)  [delta-membrane-systems-ltd](https://www.linkedin.com/company/delta-membrane-systems-ltd)  [deltamembranesystems](https://www.youtube.com/deltamembranesystems)