



## INSTALLATION GUIDE

# Delta Dual 800 Groundwater Packaged Pumping Stations



[www.deltamembranes.com](http://www.deltamembranes.com)

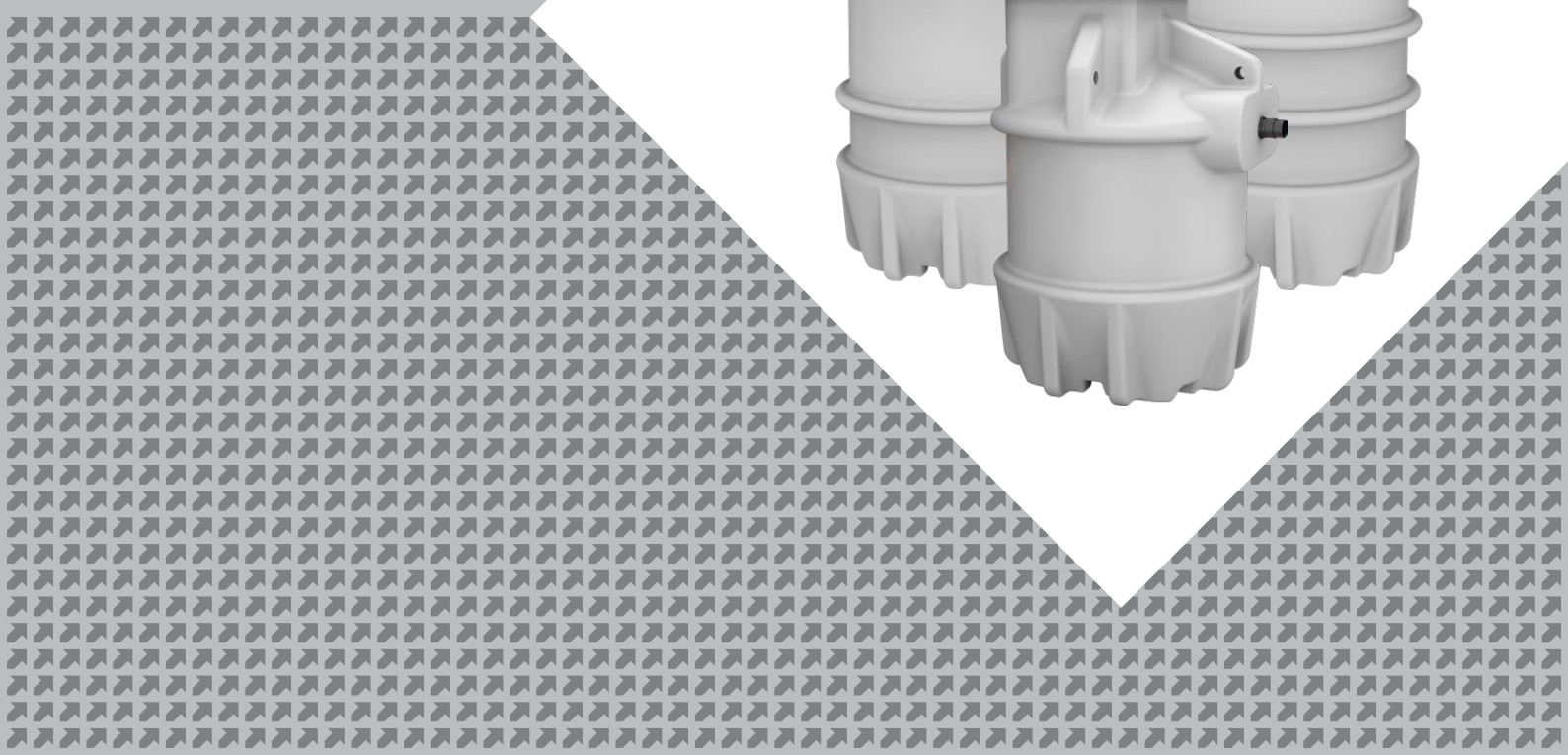

**THIS MANUAL SHOULD BE KEPT WITH  
THE PUMP STATION OR THE HOMEOWNER**

# Contents

1.	Delta Dual 800 Groundwater Series .....	1
1.1	Delta Dual 800 Groundwater Series packaged pumping stations overview .....	1
1.2	Example installation .....	1
1.3	Parts included .....	2
1.4	Optional extras.....	2
1.5	Pump specifications .....	2
1.6	Chamber specifications .....	2
2.	Discharge pipework and fittings .....	5
2.1	Discharge pipework and fittings.....	5
2.2	Spare parts.....	6
3.	Chamber depth limits .....	7
4.	Installation guidelines.....	8
4.1	Installation guidelines .....	8
4.2	Pump station location .....	8
4.3	Installation within a reinforced concrete sump.....	8
4.4	Cable duct guidance.....	9
4.5	Vent duct guidance.....	9
4.6	Installation procedure .....	10
5.	Lifting guide .....	12
6.	Wiring diagrams.....	13
6.1	Wiring diagram with Delta HLA .....	13
6.2	Wiring diagram with Delta UPS V3 .....	14
6.3	Wiring diagram with Delta UPS V4/6.....	15
6.4	Wiring diagram with Delta Battery Backup .....	16
7.	Maintenance .....	17
8.	Health and safety .....	17
9.	Warranty .....	18
10.	Troubleshooting .....	19
11.	Ancillaries.....	20
12.	Drainage channel components.....	22
13.	Commissioning details.....	23

# 1. Delta Dual 800 Groundwater Series

## 1.1 Delta Dual 800 Groundwater Series packaged pumping stations overview

The robust and reliable Delta Dual 800 Groundwater Series packaged pumping stations have been specifically designed to collect ground and surface water from basements, below ground structures.

Typical applications include (but are not limited to) type-C cavity drained waterproofing solutions and/or surface water from roofs, buried roofs, terraces, lightwells and patios.

The systems include a polyethylene chamber, 1¼" PVC internal pipework, two Delta V3/V4/V6 submersible pumps, 110 mm inlet, 50 mm cable duct, 110 mm vent and 2" discharge.

The pump station has been specifically designed for below ground applications. The chamber is manufactured from tank-grade polyethylene and as such is extremely robust.

To prevent movement, the chamber must be installed within a waterproof reinforced concrete sump and backfilled with concrete.

An access cover is not supplied, as these are generally site specific and installed in the final finish. The chamber will accept a standard 600 mm x 450 mm cover and frame.

Inlets can easily be drilled and sealed on site, making this product straightforward to install.

Delta Dual 800 Groundwater Series package pumping stations are available in depths of 1250 mm, 1500 mm, 1750 mm and 2000 mm, and with a choice of Delta V3, V4 or V6 submersible pumps to suit project requirements.

The Delta Dual 800 Groundwater Series is not suitable for collecting foul water.

## 1.2 Example installation

- |                    |                                |
|--------------------|--------------------------------|
| A Inlet pipe       | I Cable duct                   |
| B Screed           | J Discharge pipe               |
| C Insulation       | K Basement slab                |
| D Concrete base    | L Distribution board           |
| E Vent             | M Non-switched fused spur      |
| F MS20 Membrane    | N Delta HLA                    |
| G Pump chamber     | O Volt-free contact (optional) |
| H Inspection cover |                                |

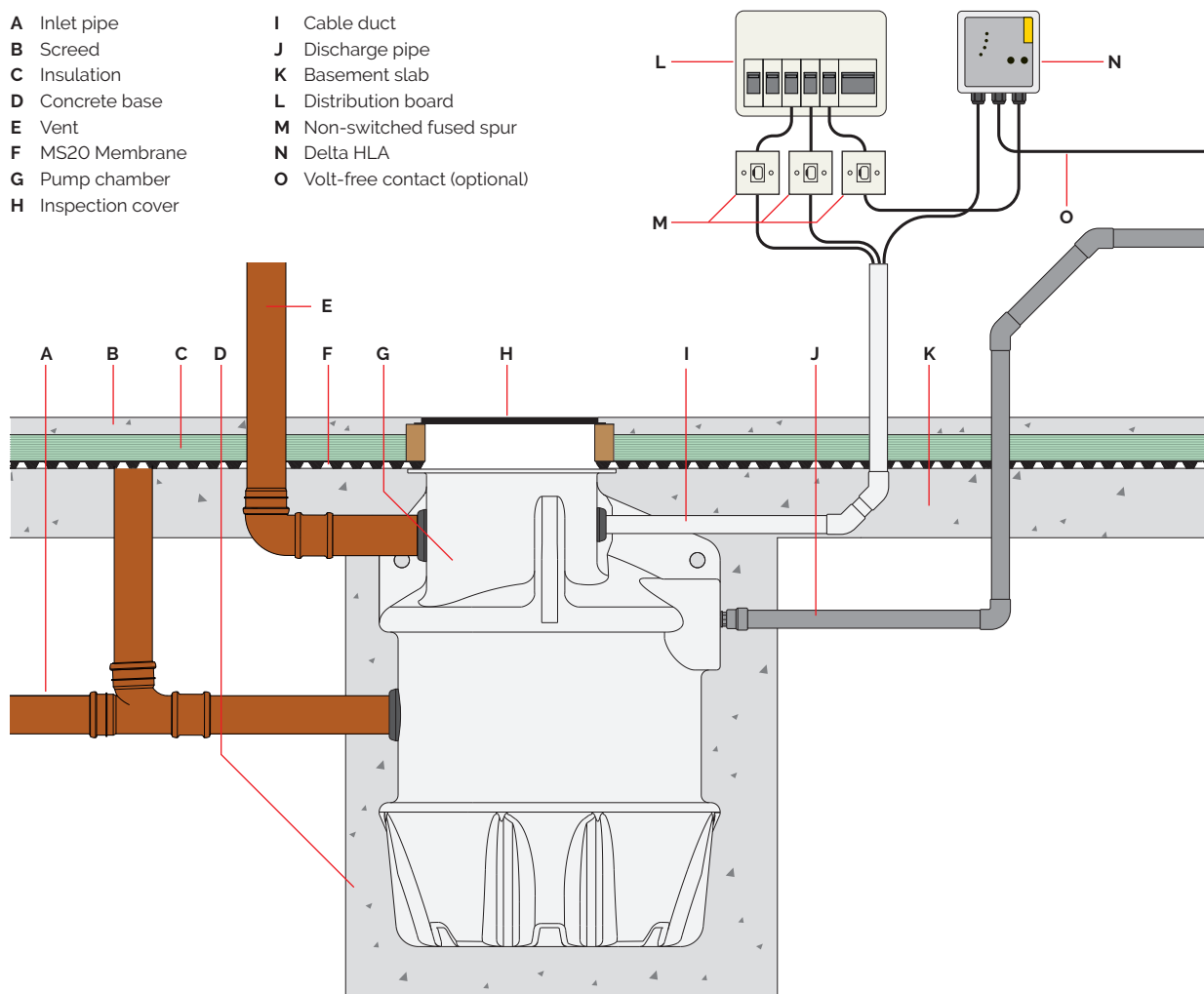

*For illustration purposes only.*

### 1.3 Parts included

- Chamber – 900mm diameter (OD) by 1250/1500/1750/2000 mm deep
- 1.25" internal pipework
- 2 x Delta V3/4/6 series groundwater pumps
- 110 mm inlet
- 2" plain discharge for solvent weld to PVC pipe (Class E).
- 110 mm vent and 50 mm cable duct

### 1.4 Optional extras

- Delta HLA high level alarm (DMS 190) and Delta Sump Float Kit
- A range of battery backup systems
- Addition inlets
- 2" discharge pipework and various fittings

### 1.5 Pump specifications

Pump specification		V3	V4	V6
Impellor type		Vortex	Vortex	Vortex
Power	P <sub>1</sub> (kW)	0.43	0.75	1.05
	P <sub>2</sub> (kW)	0.18	0.36	0.50
Rated current (A)		1.9	4.0	4.9
Power phase		Single	Single	Single
Non-switched fused spur rating (A)		13	13	13
RCBO rating (A)		6	10	10
Cable length (m)		10	5	5
Max. temperature continuous (°C)		50	50	50
Weight (kg)		5.2	6.0	6.9

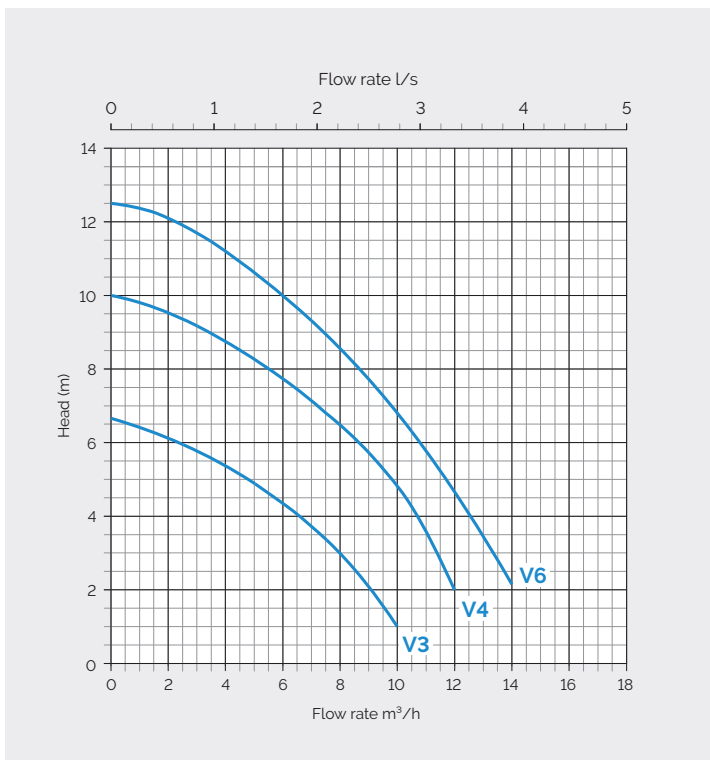

Delta V3



Delta V4



Delta V6

1. Delta Dual 800 Groundwater Series

1.6 Chamber specifications

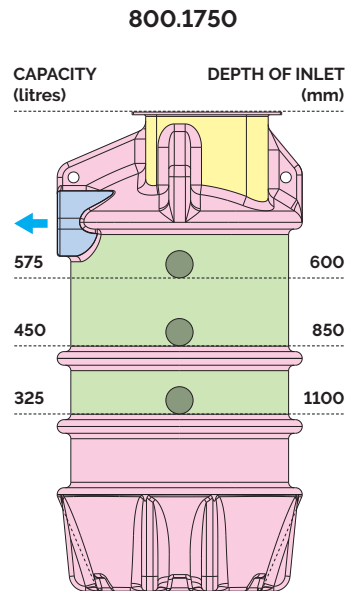
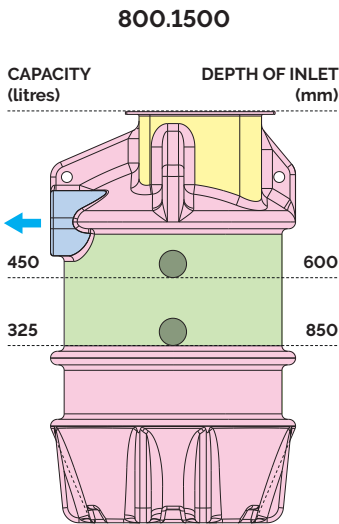
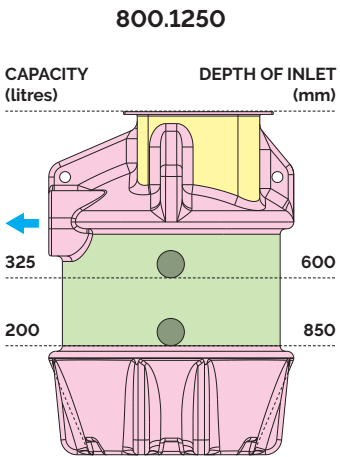
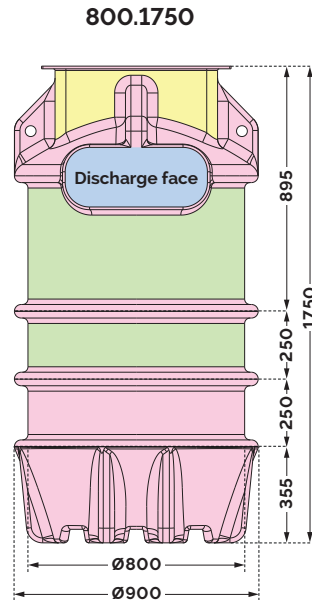
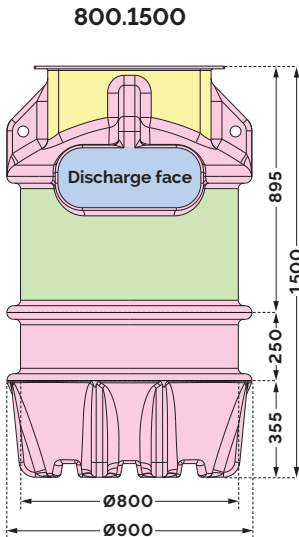
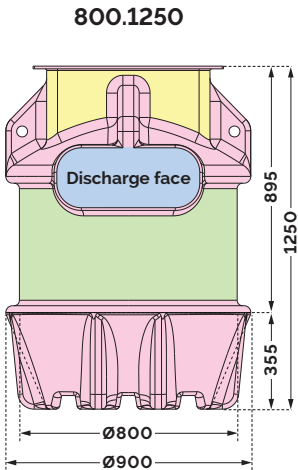

800.2000

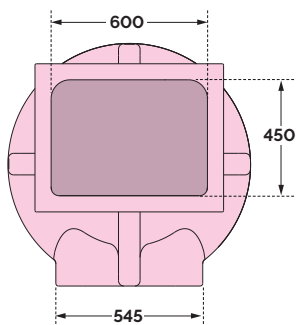
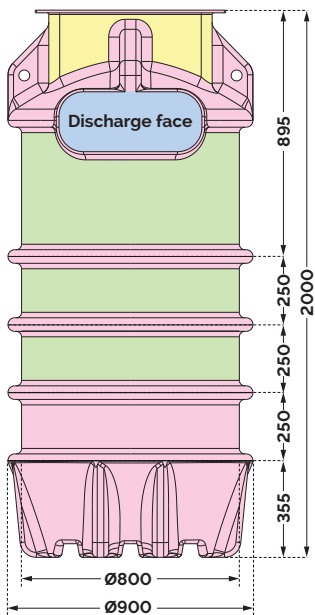

Positioning connections

Discharge only
Inlet location allowed
Cable ducts and vents only
No drilling allowed

All dimensions are in millimetres (mm). All capacities are in litres (l).

All inlet depths shown are to the invert level (bottom of pipe).



800.2000

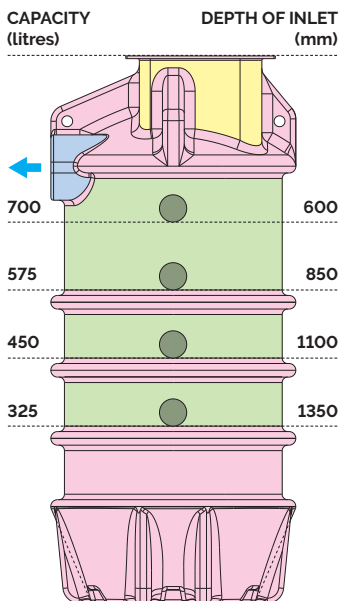

Chamber specification	
Chamber material	Tank-grade polyethylene
Inspection cover	Not supplied
Clear opening to chamber (mm)	600 x 450
Inlet (mm)	110
Cable duct (mm)	50
Vent (mm)	110
External discharge connection	2" high pressure PVC Class E
Internal pipework manifold	1.25" high pressure PVC Class E

# 2. Discharge pipework and fittings

## 2.1 Discharge pipework and fittings

A selection of discharge pipework and fittings are available for the Delta Dual 800 Groundwater series.

Should you require to place an order for any of these items, please complete the form below, scan and email to pumps@deltamembranes.com to allow us to process your order.

Product	DMS Code	Qty req.
2" pressure pipe PVC Class E (2 m)	DMS E120	<input type="text"/>
90 degree elbow PL/PL, 2"	DMS E121	<input type="text"/>
45 degree elbow PL/PL, 2"	DMS E122	<input type="text"/>
Coupling (socket) PL/PL, 2"	DMS E123	<input type="text"/>
Coupling (socket) PL/TH, 2"	DMS E127	<input type="text"/>
Coupling (socket) TH/TH, 2"	DMS E131	<input type="text"/>
Male threaded adaptor (male iron), 2"	DMS E124	<input type="text"/>
50 mm male iron, low pressure	DMS E132	<input type="text"/>
Saddle clamp, 110 mm x 2" BSP female thread)	DMS E133	<input type="text"/>
2" pipe clip, PP, black	DMS E202	<input type="text"/>
Solvent cement, WDF-05, 250 ml	DMS E175	<input type="text"/>
PVC cleaning fluid, 500 ml, tin	DMS E176	<input type="text"/>
PTFE tape, roll	DMS E177	<input type="text"/>

Name:	
Company name:	
Delivery/site address:	
Email:	
Telephone number:	Mobile Number:

Signature:	Date:
------------	-------

**Please scan this order form and email to pumps@deltamembranes.com**



## 2.2 Spare parts

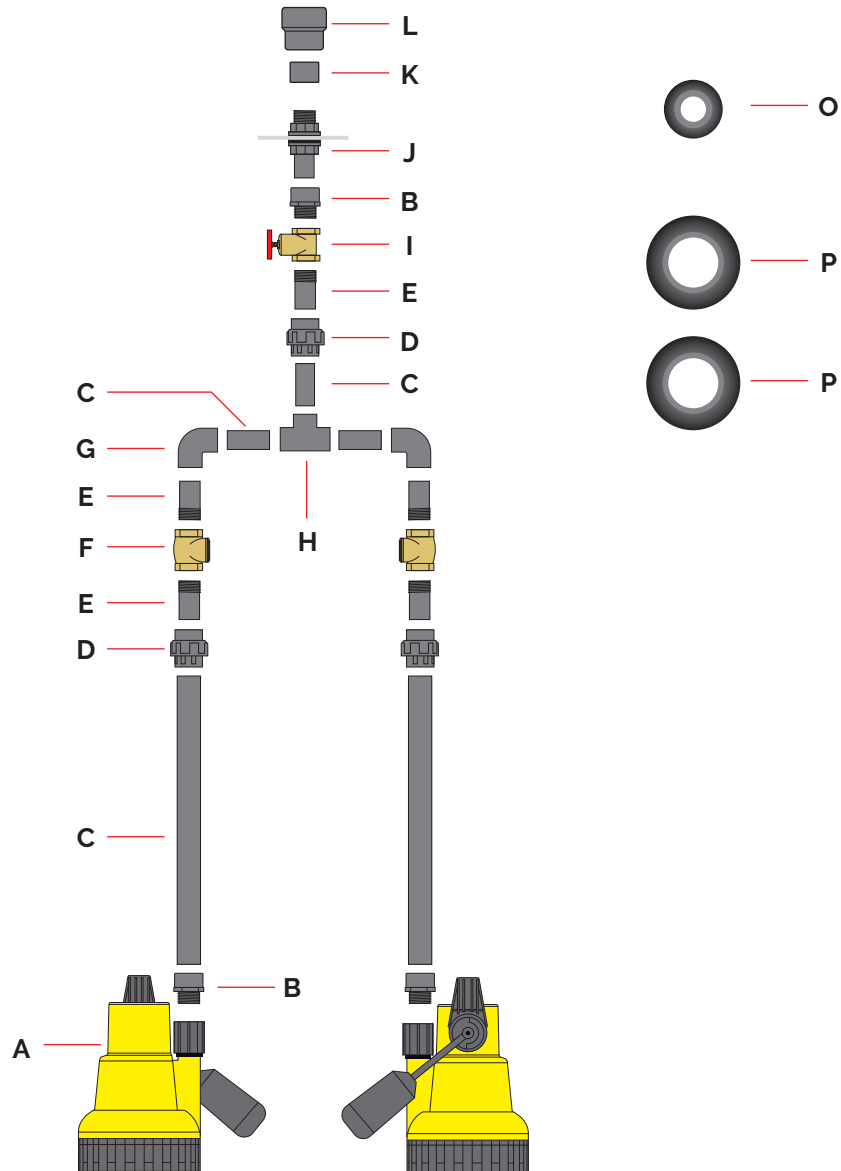

Part	Description	DMS Code
A	Delta V3/V4/V6 Submersible Pump, incl: – float switch assembly (DMS 192) – non-return valve (DMS 195)	DMS 116 (V3) DMS 216 (V4) DMS 084 (V6)
B	Male threaded adaptor, 1.25"	DMS E104
C	High pressure PVC pipe (Class E), 1.25"	DMS E100
D	Socket union, 1.25" c/w 'O' ring	DMS E106
E	Barrel nipple PL/TH, 1.25"	DMS E108
F	Brass swing check valve, 1.25"	DMS E191
G	90° elbow, 1.25"	DMS E101

Part	Description	DMS Code
H	Tee-piece, 1.25"	DMS E105
I	Brass gate valve, 1.25"	DMS E187
J	Tank connector, 1.25"	DMS E110
K	Reducing bush, PL/TH, 1½" to 1¼"	DMS E161
L	Reducer, PL/PL, 2" to 1½"	DMS E160
O	Rubber wall seal, 50 mm (cable duct, 50 mm inlets)	DMS E168
P	Rubber wall seal, 110 mm (vent duct, 110 mm inlet)	DMS E169

# 3. Chamber depth limits

The chamber must be installed less than 300 mm below the finished floor level (FFL) so that it can be serviced safely in accordance with the Construction (Design and Management) Regulations 2015 (CDM).

If the inlet inverts to not allow installation within this depth limit, please discuss chamber options with us on 01992 523 523 between 8am and 5pm, Monday to Friday or by email at [info@deltamembranes.com](mailto:info@deltamembranes.com) before proceeding.

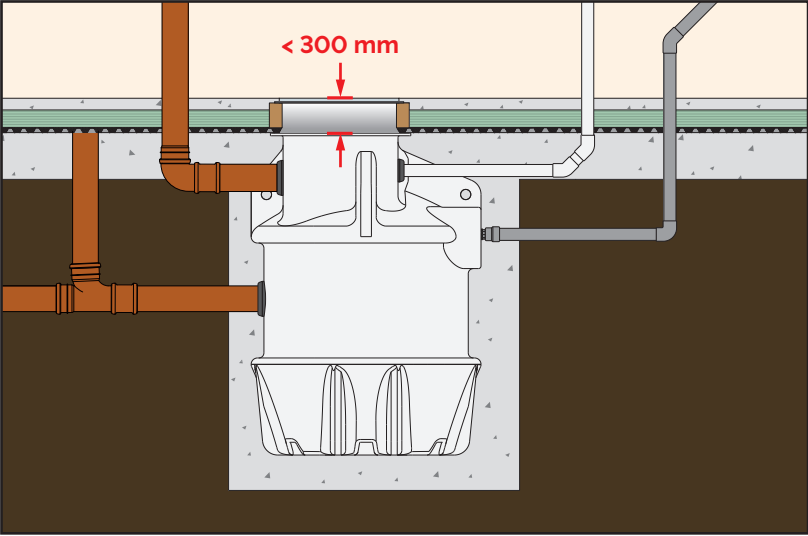

**Less than 300 mm below FFL**

The chamber must be installed no greater than 300 mm below FFL.

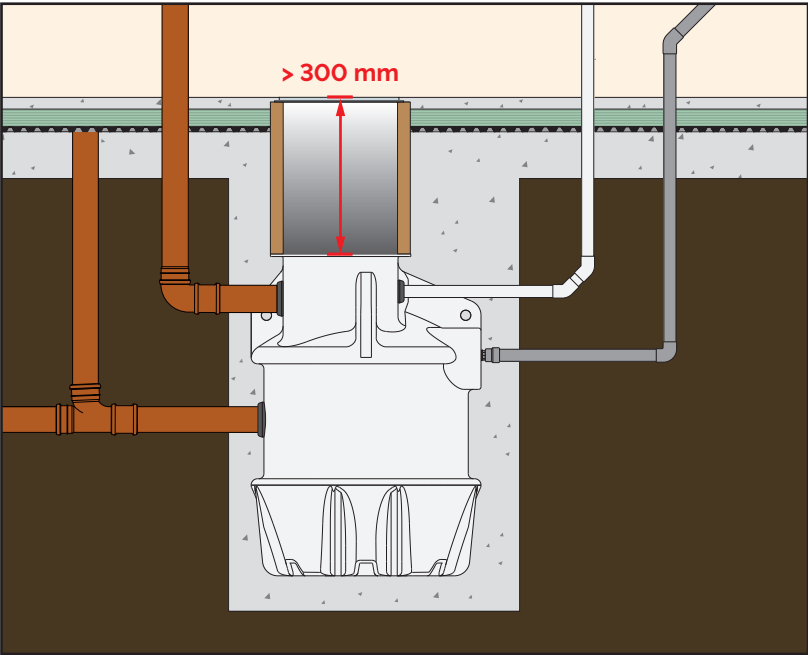

**More than 300 mm below FFL**

The chamber must not be installed at a depth below FFL greater than 300 mm.

It cannot be serviced safely in accordance with The Construction (Design and Management) Regulations 2015.



# 4. Installation guidelines

## 4.1 Installation guidelines

This guide is an illustration of installation guidelines which should be followed for proper installation of the Delta Dual 800 Groundwater Packaged Pumping Stations, including housing. It is important to note these instructions are for guidance only and it is the installer's responsibility to satisfy themselves that the installation procedure is in accordance with the prevailing ground conditions and good build practice, to eliminate any potential damage to the pump station chamber either during or after installation. The installer should also satisfy themselves that the system can be installed in conjunction with these guidelines, prior to work commencing.

Please read these instructions in full before beginning the installation. If you are unsure on any point then contact Delta Membranes on 01992 523 523 between 8am and 5pm, Monday to Friday or by email at [info@deltamembranes.com](mailto:info@deltamembranes.com) before proceeding.

## 4.2 Pump station location

The Delta Dual 800 Groundwater Packaged Pumping Stations require routine maintenance. It is important that careful consideration is taken to position the chamber in a location which will allow for permanent access.

## 4.3 Installation within a reinforced concrete sump



**A structural and waterproofing engineer must be consulted when designing the waterproof reinforced concrete sump and backfill to ensure that it can withstand the anticipated pressures, and that they are not transferred onto the chamber.**

The chamber is manufactured from tank-grade polyethylene and is extremely robust. However, as with all pre-formed chamber they are susceptible to floatation and hydrostatic pressures exerted in high water table conditions.

To ensure these forces are not transferred onto the chamber, the chamber must be installed within a waterproof reinforced concrete (RC) sump.

Furthermore, when constructing the waterproof reinforced concrete sump, adequate space must be made for connections to the chamber e.g. inlets, discharge, cable and vent ducts. Consideration must also be made to the depth and orientation of all connections to ensure that they line up with the chamber.

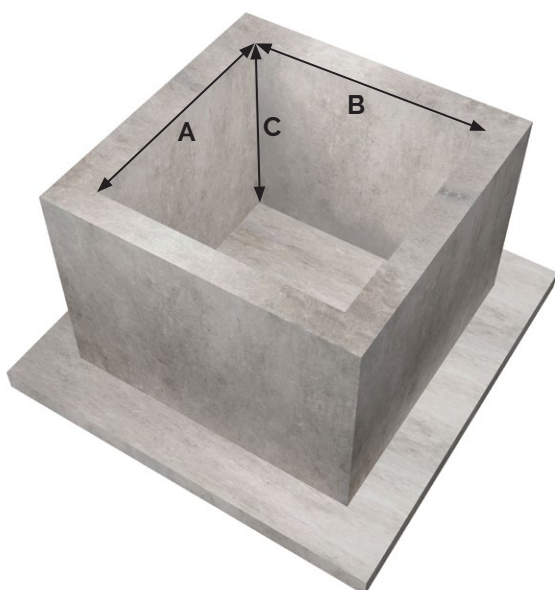

*Recommended RC sump dimensions*

Chamber	A (mm)	B (mm)	C (mm)
800.1250	1300	1300	1255
800.1500	1300	1300	1505
800.1750	1300	1300	1755
800.2000	1300	1300	2005

## 4. Installation guidelines

### 4.4 Cable duct guidance

The cable duct for the Delta Dual 800 Groundwater packaged pumping station should be 50 mm diameter. This can be constructed of low pressure ABS waste pipe or high pressure PVC. A 50 mm rubber wall seal is supplied to connect the cable duct to the chamber. The cable duct can be positioned on any flat face of the chamber neck. Please refer to Section 1.6.

#### 4.4.1 CONSTRUCTING THE CABLE DUCT

To allow cables to be easily pulled through the cable duct use sweeping corners instead of tight 90 degree elbows. These can be created by using two 45 degree elbows.

It is vital to pull a draw cord through the cable duct as it is being constructed.

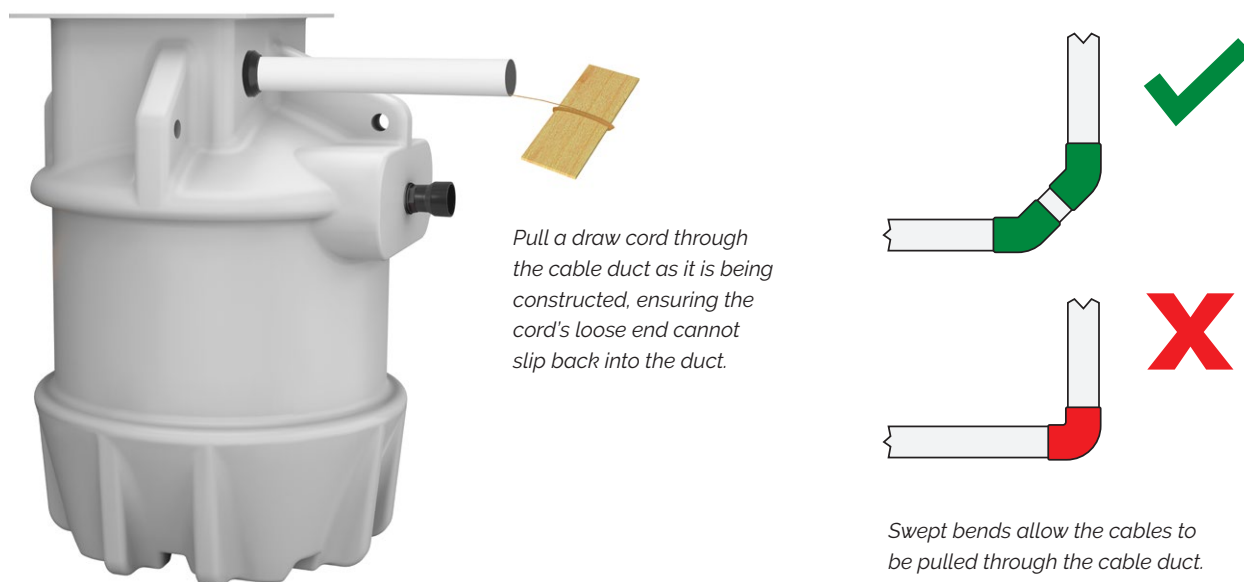

#### 4.4.2 CABLE EXTENSIONS

If cable extensions are required for the pump power cables or the float cable, a qualified electrical contractor must make all electrical connections. Suitable cable extension kits are available to order. Please contact Delta Membranes on 01992 523 523 between 8am and 5pm, Monday to Friday or by email at [info@deltamembranes.com](mailto:info@deltamembranes.com) for more information.

### 4.5 Vent duct guidance

If the pumping station receives surface water, for example from a lightwell, a vent duct must be installed. This duct must be vented to atmosphere. An air-admittance (Durgo) valve must not be installed. The vent duct's primary purpose is to equalise pressure within the chamber. It will also mitigate any odours from stagnant surface water in the base of the chamber.

The vent duct should be 110 mm waste pipe. A 110 mm rubber wall seal is supplied to connect the vent duct to the chamber. The vent duct can be positioned on any suitable flat face of the chamber neck. Please refer to Section 1.6.

A vent duct is **not required** if the chamber only accepts groundwater from a cavity membrane system.

## 4.6 Installation procedure

Please read these instructions in full, prior to commencement of the installation. If you are unsure on any point then contact Delta Membranes on 01992 523 523 between 8am and 5pm, Monday to Friday or by email at [info@deltamembranes.com](mailto:info@deltamembranes.com) before proceeding.

1. Select a suitable location for the pumping station. Where possible, installation of a pumping station in a roadway should be avoided due to the need for periodic maintenance of the pumps contained therein. If the location is adjacent to a roadway, the installation method should take into account the imposed loads likely to be transmitted to the chamber by traffic etc.
2. Construct a suitable waterproof reinforced concrete (RC) sump (please refer to Section 4.3 for details).
3. Lift the chamber into the RC sump (please refer to Section 5) and position it such that all connections are correctly aligned. Mark all connections and remove the chamber from the RC sump.
4. Install the rubber seals into the chamber wall for the 50 mm cable duct, 110 mm vent duct, and the inlet(s). The size and number of inlets is project dependent (one 110 mm rubber wall seal is supplied as standard for inlets).

All connections should be aligned square to the chamber enabling the seals to remain watertight .



**ENSURE A DRAW CORD IS PULLED THROUGH THE CABLE DUCT AS THE CABLE DUCT IS BUILT. PLEASE REFER TO SECTION 4.4.**

5. Lay a WET mass concrete into the base of the RC sump to a thickness of 100 mm,
6. Lift the chamber into the excavation (please refer to Section 5) and carefully position it onto the WET mass concrete base ensuring that no loose debris is inadvertently knocked onto the base under the chamber during this procedure.

Manipulate the chamber so that it sits on the base of the RC sump then position it so that the inlet(s), cable duct, vent and discharge connections are correctly aligned.

7. Once the chamber is positioned, connect the 50 mm cable duct, 110 mm vent duct and inlet pipework to the chamber (please use fittings supplied). The discharge pipework can then be connected. The discharge pipework should be able to withstand high pressure (PVC Class E or MDPE),
8. The vent duct should be vented to atmosphere; no air admittance (Durgo) valve to be used.
10. Whilst the concrete base is still WET, backfill the space between the chamber and the RC sump to the top of the chamber with WET mass concrete in a single pour. The concrete must be evenly poured around the chamber ensuring that no voids are left within the concrete.

During the backfilling process the chamber should be ballasted by steadily filling it with water. The difference in level between the concrete backfill and the water ballast should always be less than 300 mm.



**TO PREVENT THE CHAMBER FROM FLOATING UP WHEN THE RC SUMP IS BACKFILLED, THE CHAMBER MUST BE BALLASTED WITH WATER AT THE SAME RATE AS BACKFILLING. THE LEVEL DIFFERENCE BETWEEN THE WATER AND BACKFILL MUST NOT EXCEED 300 mm AT ANY TIME.**

Care must be taken to ensure that any pipes (or other connections) are not damaged. During the concrete pour, ensure that the chamber is vertical (by using a spirit level across the chamber's opening). Additionally, ensure that the chamber remains at the correct depth level.

## 4. Installation guidelines

11. Allow time for the concrete to cure completely, then remove the ballast water.



**THE BALLAST WATER INSIDE THE CHAMBER SHOULD NOT BE REMOVED UNTIL THE BACKFILL HAS FULLY SET.**

12. Fit the access cover (not supplied) onto the top of the access shaft so that it is flush with finished floor level.
13. In a roadway application, the chamber should be installed with the top of the access shaft 300 mm below the finished cover level ensuring that the slab is supported by consolidated backfill. A suitably rated access cover should be embedded into the reinforced cover slab (to be specified at time of order). It should not bear on undisturbed ground around the excavation nor directly onto the chamber, so that imposed loads are deflected away from the chamber. Design of the cover slab is the responsibility of the installer/structural engineer.
14. Once the chamber has been installed and the ballast water has been drained, it is extremely important that all sand, silt, rubble and general debris is removed from the chamber.



**FAILURE TO REMOVE SAND, SILT, RUBBLE AND ALL OTHER DEBRIS FROM THE CHAMBER WILL INVALIDATE THE WARRANTY ON THE PUMPS.**

15. Partly refill the chamber with clean water for testing the system upon commissioning, and so that the discharge pipe can be flushed through.
16. Install the pumps and high level alarm float switch and draw these cables through the cable duct.
17. Install the Delta HLA high level alarm. Please refer to the Delta HLA installation guide.
18. Provide suitable electrical connections (refer to wiring diagrams in Section 6).



**A QUALIFIED ELECTRICIAN MUST CARRY OUT ALL ELECTRICAL CONNECTIONS.**

19. Commission the pumping station. If you require a commissioning service please contact Delta Membranes on 01992 523 523 between 8am and 5pm, Monday to Friday or by email at [info@deltamembranes.com](mailto:info@deltamembranes.com).



**When commissioning the system check that all socket unions are fully tightened and not leaking. If a leak is detected, undo the socket union and check that its O-ring is seated correctly, then re-tighten. Do not overtighten as this can damage the fitting.**

# 5. Lifting guide



These instructions must be followed to prevent injury to operatives or damage to the product.

- Create a lifting plan, noting the following specifics, to prevent injury to operatives or damage to the product during the lifting process.
- Refer to the individual pallet / product's weight sticker and make sure the lifting equipment is suitable for this weight.
- Inspect all the chamber's lifting eyes.
- Do not use chains. The product must be lifted using a 4-hook lifting spreader beam with the correct length and breadth for the widths of the chamber's lifting eyes.
- Under no circumstances should the lifting equipment impinge on the clear opening flange. This will apply pressure to the flange and will damage the chamber.
- Adhere to all current legislative and training requirements.

If you require further advice contact Delta Membranes on 01992 523 523 between 8am and 5pm, Monday to Friday or by email at [info@deltamembranes.com](mailto:info@deltamembranes.com) before attempting to lift the product.

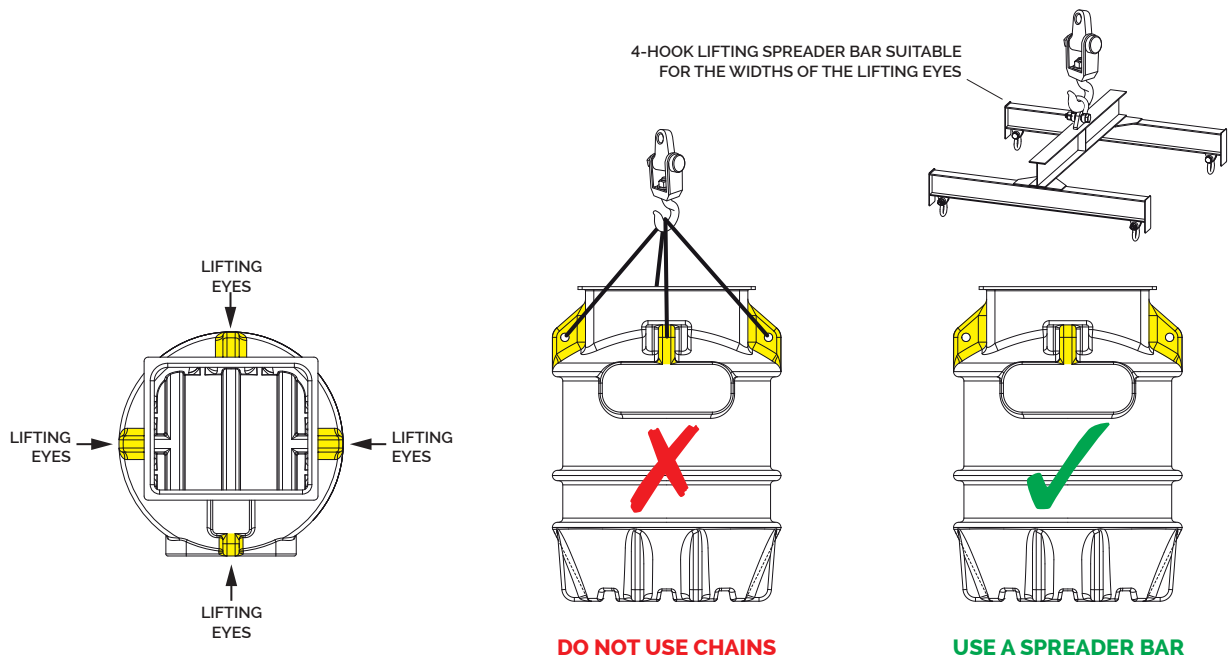

# 6. Wiring diagrams

## 6.1 Wiring diagram with Delta HLA

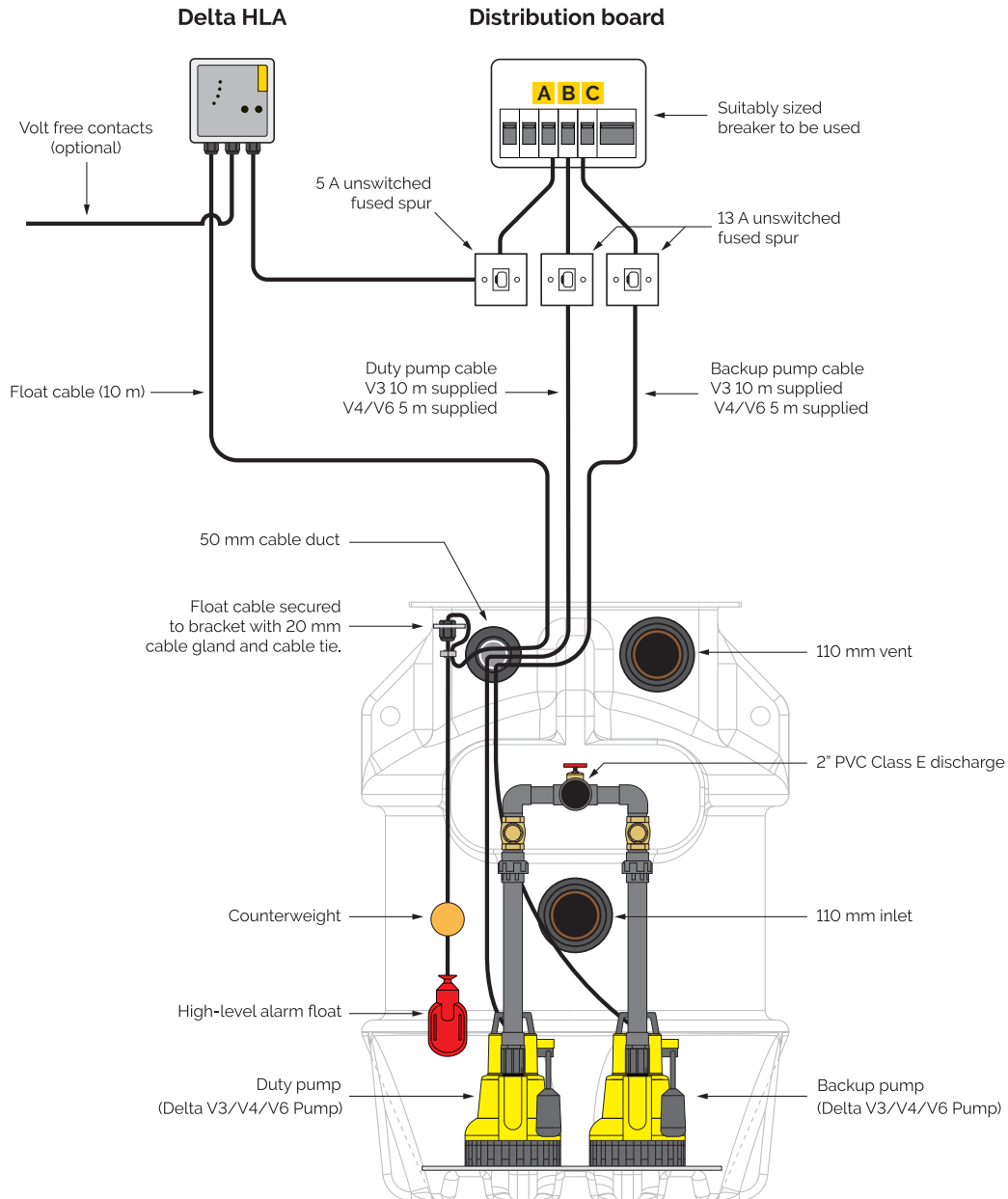

### BREAKER SPECIFICATION

Description	Device type	Rating
A Delta HLA	MCB	6 A
B Delta V3/4/6 Pump	RCBO, Type C	6 A (V3) or 10 A (V4/6)
C Delta V3/4/6 Pump	RCBO, Type C	6 A (V3) or 10 A (V4/6)



## 6.2 Wiring diagram with Delta UPS V3

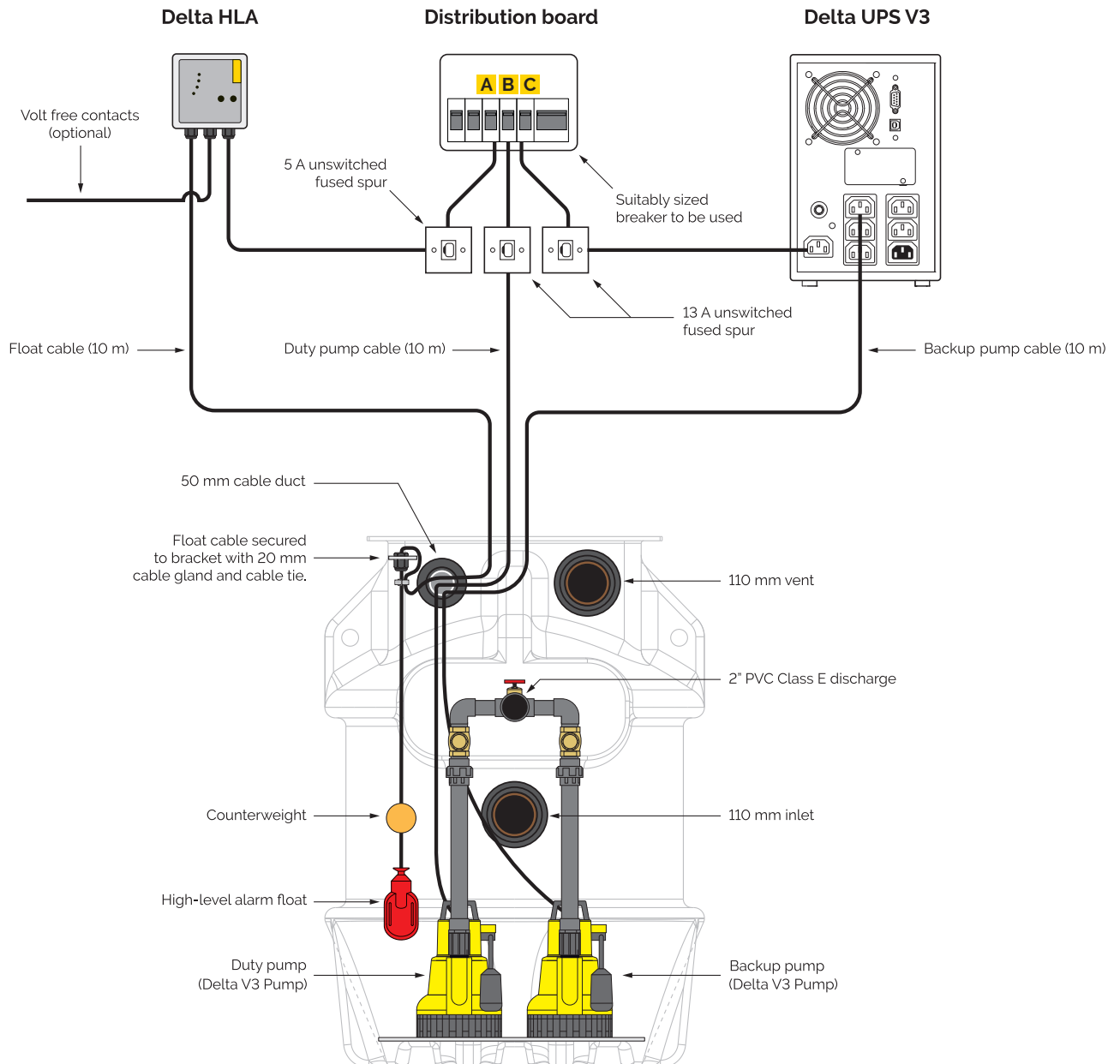

### BREAKER SPECIFICATION

Description	Device type	Rating
A Delta HLA	MCB	6 A
B Delta V3 Pump	RCBO, Type C	6 A
C Delta UPS V3	RCBO, Type C	6 A

## 6. Wiring diagrams

### 6.3 Wiring diagram with Delta UPS V4/6

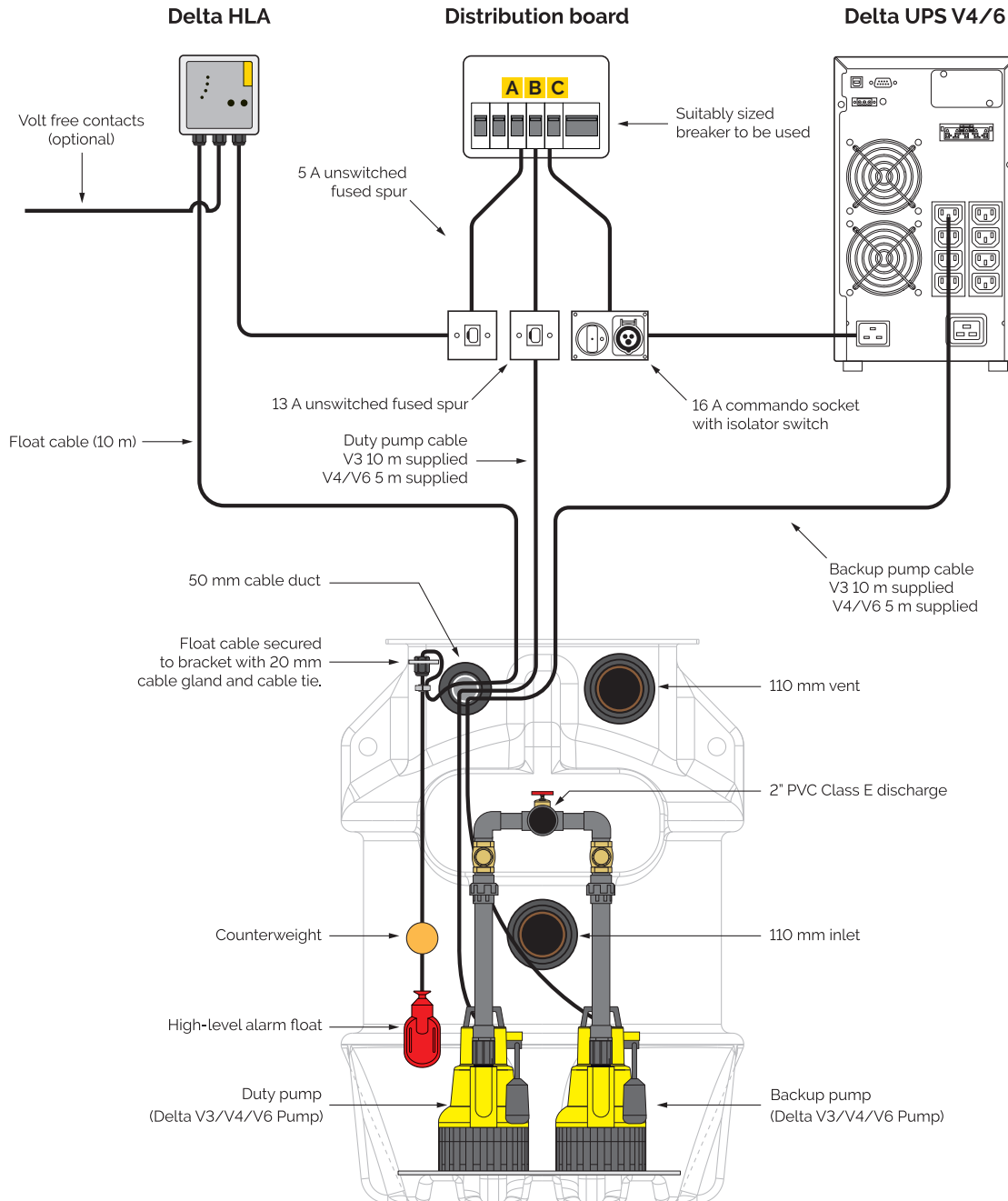

#### BREAKER SPECIFICATION

Description	Device type	Rating
A Delta HLA	MCB	6 A
B Delta V3/4/6 Pump	RCBO, Type C	6 A (V3) or 10 A (V4/6)
C Delta UPS V4/6	RCBO, Type C	16 A

6.4 Wiring diagram with Delta Battery Backup

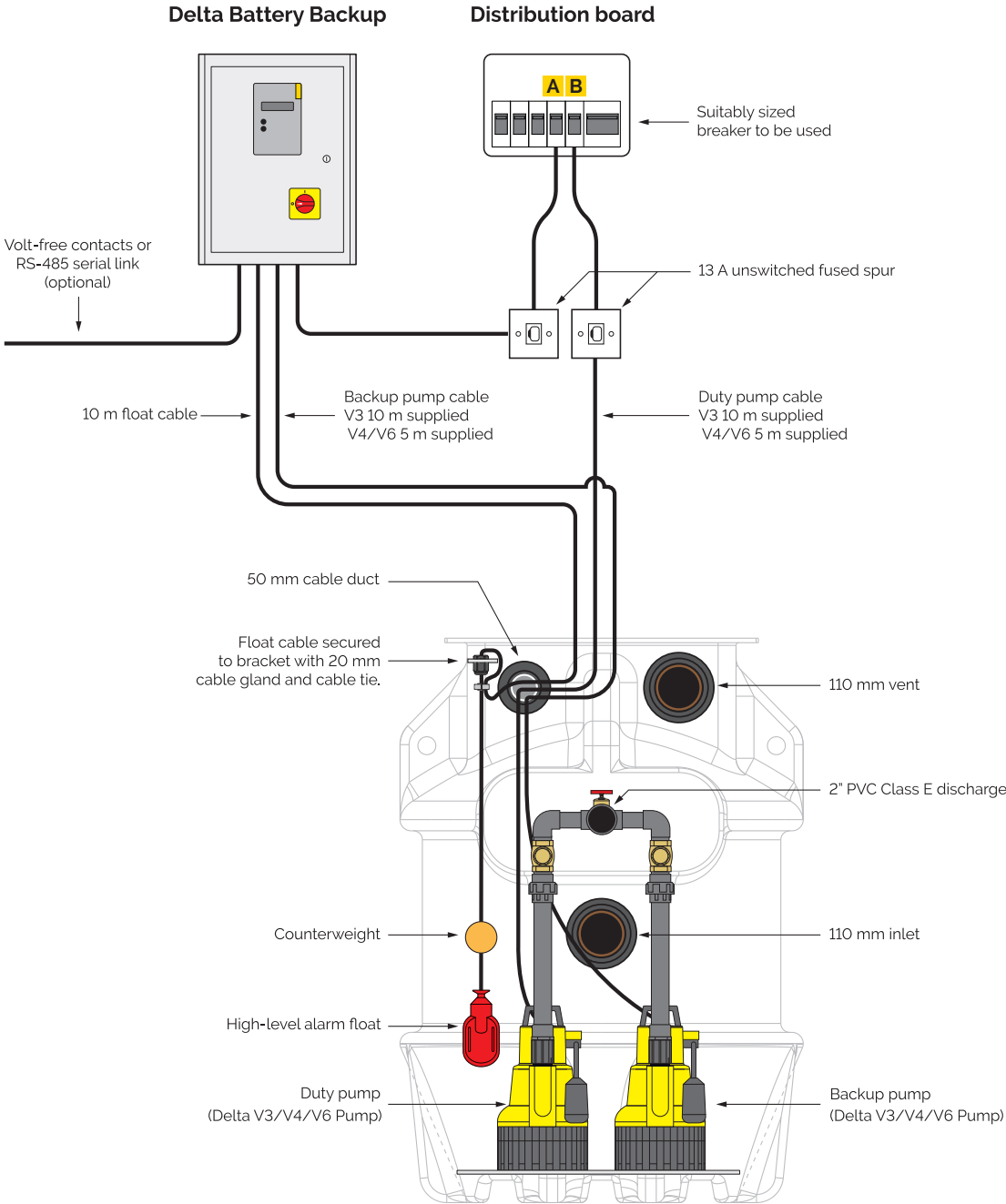

**BREAKER SPECIFICATION**

Description	Device type	Rating
A Delta Battery Backup	RCBO, Type C	6 A (V3) or 10 A (V4/6)
B Delta V3/4/6 Pump	RCBO, Type C	6 A (V3) or 10 A (V4/6)

# 7. Maintenance

Sump pumps must be maintained. We recommend a qualified engineer examines and services equipment every year. Pumps running frequently due to higher water table, water drainage, or weather conditions should be examined more frequently, we recommend every 6 months. Sump pumps, being mechanical devices, may fail if not maintained which could lead to a flooded basement and costly repairs.

Regular servicing of sump pumps will increase efficiency and extend the life of the pump. All Delta pump systems should be maintained by one of our Delta Registered Pump Service Providers or installing contractor.

# 8. Health and safety

In order to minimise the risk of ill health or accidents when installing and/or servicing pump chambers, workers must be fully trained, competent and follow the health and safety guidelines below:

- Do not work without a risk assessment being in place.
- Work in accordance with the control measures identified in the risk assessment.
- All personnel must be vaccinated against diseases to which they may be exposed to, i.e. Tetanus, Polio, Hepatitis A&B, etc.
- At the time of writing, due to there being no vaccine against leptospirosis/Weil's disease, where rats may be present, ensure appropriate personal protective equipment (skin protection) is worn and ensure any cuts or abrasions are fully covered.
- There should be no eating or drinking during works and only afterwards following a change of clothing and washing.
- Ensure electrical power to the pump is turned off/isolated before carrying out installation or maintenance.
- A suitable first aid kit must be close to hand.

# 9. Warranty



## 9.1 Standard 12-month component warranty

The Delta Dual 800 Groundwater Packaged Pumping Station is offered with a 12-month component warranty from the date of invoice. This does not include submersible pumps, which have a standard 24-month warranty (refer to Section 9.2).

Standard Delta Membrane Systems Limited conditions apply.

This warranty does not cover defects caused by incorrect installation, installation/installer error, abnormal working conditions, misuse, or neglect.

Any defects or malfunctions should be reported to Delta Membrane Systems Limited within 7 days of when the defect becomes apparent. All broken components should be returned to Delta Membrane Systems Limited at customer cost.

To make a Warranty Claim, please email [pumps@deltamembranes.com](mailto:pumps@deltamembranes.com). Forms are available from [www.deltamembranes.com](http://www.deltamembranes.com).

In no event shall Delta Membrane Systems Limited be liable for any consequential damage, penalties, loss, or expenses howsoever arising, out of or in connection with incorrect installations or misuse, including, without limitation, direct or indirect loss, consequential loss or damage, loss of profit or goodwill, loss arising from any errors or omissions in the pump chamber as a result of, incorrect installation, installation/installer error, abnormal working conditions, misuse, or neglect.

Delta Membrane Systems Limited shall not accept liability if the pumping system fails due to being incorrectly specified by any third parties not employed by Delta Membrane Systems Limited.

Delta Membrane Systems Limited shall not accept liability if the pump system fails due to discharge of inappropriate fluids/solids including, but not limited to, building debris or materials.

### 9.1.1 Warranty from date of commissioning

When the Delta Dual 800 Groundwater Packaged Pumping Station is commissioned by a Delta Registered Pump Service Provider, the 12-month warranty period will begin at date of commissioning, subject to:

- all services and associated systems are ready to enable commissioning to take place;
- commissioning has been undertaken within 12 months from the date of invoice;
- the Delta 800 Groundwater Packaged Pumping Station is commissioned by a Delta Registered Pump Service Provider;
- the Delta Registered Pump Service Provider has logged Commissioning details of the Delta 800 Groundwater Packaged Pumping Station with Delta Membrane Systems Limited;
- the Delta 800 Groundwater Packaged Pumping Station is serviced by a Delta Registered Pump Service Provider with a minimum of a yearly Service (within 12 months from the date of commissioning/last service) depending on site specifications.

## 9.2 Standard 24-month pump warranty

Delta V3/4/6 Pump(s) are offered with a standard 24-month warranty from date of invoice. In other respects the terms of the pump warranty are the same as the standard component warranty.

When a Delta V3/4/6 Pump is commissioned, and then serviced regularly by a Delta Registered Pump Service Provider an extended 5-year pump warranty is offered (subject to the terms and conditions).

### 9.2.1 Five-year extended pump warranty from date of commissioning



Delta Membrane Systems Limited will offer a 5-year extended pump warranty on the Delta V3/4/6 Pump(s) from date of commissioning, subject to:

- all services and associated systems are ready to enable commissioning to take place;
- the Delta V3/4/6 Pump(s) is commissioned within 12 months from the date of invoice;
- the Delta V3/4/6 Pump(s) is commissioned by a Delta Registered Pump Service Provider;
- the Delta Registered Pump Service Provider has logged Commissioning details of the Delta V3 pump(s) with Delta Membrane Systems Limited;
- all Delta V3/4/6 Pump(s) registered under the extended 5-year warranty must be serviced by a Delta Registered Pump Service Provider with a minimum of a yearly Service (within 12 months from the date of commissioning/last service) depending on site specifications.

# 10. Troubleshooting

Please ensure the installation process has been completed thoroughly and all steps have been followed correctly.

Use the table below to assist with troubleshooting and if problems still occur, please contact Delta Membranes on 01992 523 523 between 8am and 5pm, Monday to Friday or by email at [info@deltamembranes.com](mailto:info@deltamembranes.com) for more information.

Fault	Cause
Water is leaking from discharge arms.	<p>If the leak is from a socket union, unscrew the union and check that its O-ring is seated correctly, then re-tighten. Do not overtighten as this can damage the fitting.</p> <hr/> <p>PTFE tape not applied to male irons on discharge arms when attached to pumps.</p>
Pump isn't running.	<p>Pump hasn't got power – check wiring with reference to section 6.0 wiring diagram.</p> <hr/> <p>Float arm isn't lifting – check float arm is free moving and not catching on chamber or other pump – make sure pumps are positioned as diagram 38.</p> <hr/> <p>Float arm not turning on pump – can you hear a click when lifted slowly? If not, call Delta Technical.</p>
The pump is running but is not pumping water or is discharging very slowly (taking more than 40 seconds to empty the chamber).	<p>Gate valve isn't open or partially closed – turn valve anticlockwise to open.</p> <hr/> <p>Pump is air locked – make sure there is a level of water to the top of the pumps, remove pump from union and lower back into water, lift float arm to activate pump before reconnecting to discharge arm.</p> <hr/> <p>Discharge pipe is blocked – a drainage company is required.</p> <hr/> <p>Pump impeller is jammed – turn off power and isolate pump, remove pump from chamber, unscrew pump base using Torx screwdriver and free impeller.</p>
	<div style="background-color: #c00000; color: white; padding: 5px; text-align: center;">  <p><b>WARNING!</b>            Insure mains power and pump is isolated before taking pump apart and seek advice from a qualified electrician.</p> </div>
Pump is tripping.	<p>Pump is wired incorrectly or not on a separate supply – refer to section 6.0 wiring diagram.</p> <hr/> <p>Pump impeller is jammed – turn off power and isolate pump, remove pump from chamber, unscrew pump base using Torx screwdriver and free impeller.</p>
	<div style="background-color: #c00000; color: white; padding: 5px; text-align: center;">  <p><b>WARNING!</b>            Insure mains power and pump is isolated before taking pump apart and seek advice from a qualified electrician.</p> </div>
High level alarm is not functioning.	Refer to the high level alarm installation and operating instructions.

# 11. Ancillaries

**Pressure pipe, PVC Class E, 2 m**



1¼"    2"  
E100    E120

**Tank connector**



1¼"    2"  
E110    E130

**90° elbow PL/PL**



1¼"    2"  
E101    E121

**45° elbow PL/PL**



1¼"    2"  
E102    E122

**Tee-piece PL/PL**



1¼"    2"  
E105    E125

**Coupling (socket) PL/PL**



1¼"    2"  
E103    E123

**Socket union PL/PL**



1¼"    2"  
E106    E126

**Male threaded adaptor**



1¼"    2"  
E104    E124

**Coupling PL/TH**



1¼"    2"  
E107    E127

**Barrel nipple PL/TH**



1¼"    2"  
E108    E128

**Barrel nipple TH/TH**



1¼"    2"  
E109    E129

**Coupling TH/TH**



1¼"    2"  
E111    E131

# 11. Ancillaries

**Reducer, PL/PL**



2" to 1½"  
E160

**Reducing bush, PL/TH**



1½" x 1¼"  
E161

**110mm saddle clamp, reinf.**



1¼"      2"  
E113      E133

**Gate valve, brass**



1¼"      2"  
E187      E188

**Swing check valve, brass**



1¼"      2"  
E191      E193

**Non-return valve**



V3/4/6  
E195

**110mm adaptor**



1¼"      2"  
E205      E206

**Rubber wall seal**



50 mm    110 mm    160 mm  
E168      E169      E170

**Solvent cement, WDF-05**



250 ml  
E175

**PVC cleaning fluid**



500 ml  
E176

**PTFE tape, roll**



12 mm x 12 m  
E177



# 12. Drainage channel components

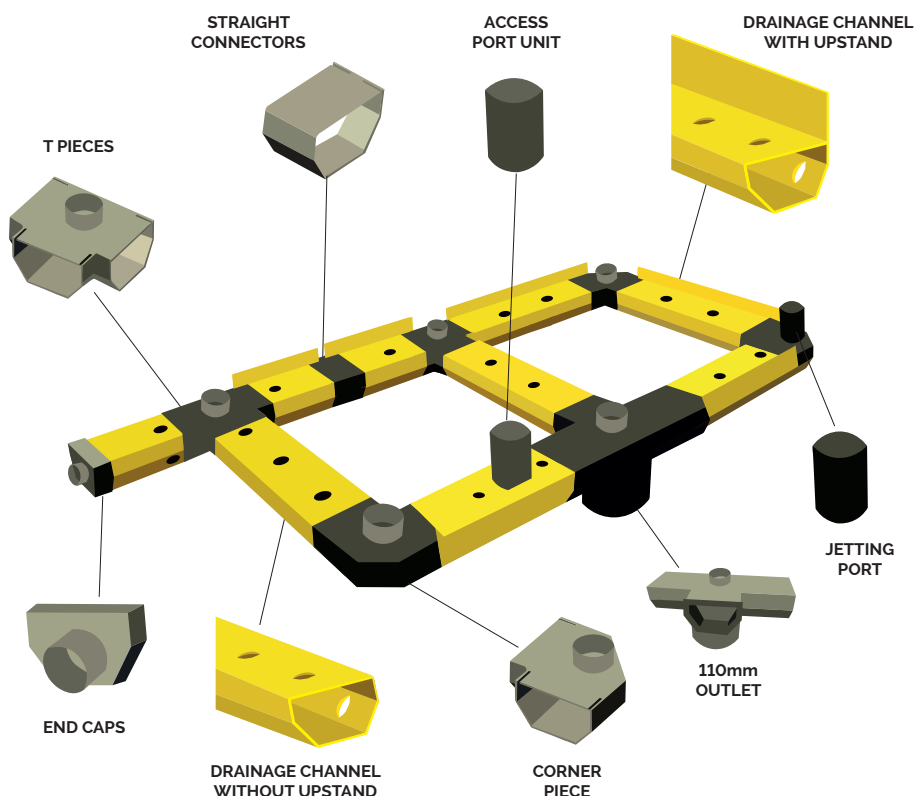

## **STRAIGHT CONNECTORS** DMS 310

Straight Connectors for connecting Delta channel (with or without upstand). Also known as Delta "in line". The range of Delta drainage channel ancillary components make installation more efficient and quicker.

## **DRAINAGE CONNECTOR** DMS 118

Drainage Connector used for connection underneath/underside of channel. Ideal for continuous waterproofing at level changes. Connects to 40mm pipe enabling drainage channel connection from below.

## **CORNER PIECES** DMS 182

Delta "90 degree" Corner Connector with "Push Out" feature for inspection port. Can be used to join lengths of Delta channels on both internal and external corner sections.

## **T PIECES** DMS 183

T Pieces, also known as "tee connectors", facilitates crossing 3 channels together to dissect the floor or to discharge to a centrally located sump pump. The T Pieces include a "Push Out" feature for inspection port, to service the system.

## **110mm OUTLET** DMS 128

110mm Drainage Outlet is designed to join the channel to 110mm standard underground pipe. The 110mm Drainage Outlet consists of a 90° PVC bend and a PVC male coupling which is fitted to the base of Delta Channel to allow water to travel from the conduit to the water collection point (sump pump). The 110mm Drainage Outlet can also accept an inspection port and has the ability cross floor channels.

## **DRAINAGE CHANNEL WITHOUT UPSTAND** DMS 208

Delta Perimeter Drainage Channel is a component part used within a Type C Cavity Drainage System. Delta Channel is a distinctive yellow, PVC drainage conduit designed to manage water ingress and hydrostatic water pressure in basements and below ground structures. Channel without upstand is used where cross channels sit over construction joints in the middle of the floor, when Delta Channel is to be offset from the wall or to join two perimeter channels together across a floor.

## **END CAPS** DMS 184

End Caps have a dual role and can work as either a blanking plate (at the far end of a channel run) or can be converted easily (with their "Push Out" feature) for easy fit of drainage pipe outlet (connector) to join with the sump pump station.

## **JETTING PORT** DMS 094

Jetting Port is designed for use with the Delta perimeter drainage channel (with and without upstand). Jetting Port allows for maintenance, inspection and cleaning of the drainage system by using water to jet away any blockages. Typically installed at every major change of direction and/or 6/7 linear metre intervals along straight run of channel.

## **DRAINAGE CHANNEL WITH UPSTAND** DMS 207

Delta Perimeter Drainage Channel is a component part used within a Type C Cavity Drainage System. Delta Channel is a distinctive yellow, PVC drainage conduit designed to manage water ingress and hydrostatic water pressure in basements and below ground structures. Channel with upstand keeps the channel stable when abutting the Delta membrane on a perimeter wall.

## **ACCESS PORT UNIT** DMS 117

Preformed unit of Delta perimeter drainage channel with inspection port. Used to provide cleaning, inspection, and maintenance access to the Delta drainage channel system.

# 13. Commissioning details

Property address	Commissioning engineers

Customer contact details	
Contact name	
Contact telephone	

Installation details	
Equipment installed	
Delta Registered Pump Service Provider	
Date of commissioning	
Commissioning engineer	
Signature of engineer	

## Servicing plans

Sump pumps must be maintained. We recommend a qualified engineer examines and services equipment every year. Pumps running frequently due to higher water table, water drainage, or weather conditions should be examined more frequently, we recommend every 6 months. Sump pumps, being mechanical devices, may fail if not maintained which could lead to a flooded basement and costly repairs. Regular servicing of sump pumps will increase efficiency and extend the life of the pump. All Delta Membrane pump systems can be maintained and serviced by our recommended service companies or installing contractor.

## Commissioning

All sump pumps require commissioning. Commissioning provides peace of mind, knowing that the system is installed correctly and in compliance with warranty conditions. All Delta Membrane pump systems can be commissioned by our recommended service companies or installing contractor.



Delta Membrane Systems Ltd, Delta House, Merlin Way, North Weald, Epping, Essex, CM16 6HR.

01992 523 523 [info@deltamembranes.com](mailto:info@deltamembranes.com) [www.deltamembranes.com](http://www.deltamembranes.com)

 [deltamembranes](https://www.facebook.com/deltamembranes)  [deltamembranes](https://twitter.com/deltamembranes)  [delta-membrane-systems-ltd](https://www.linkedin.com/company/delta-membrane-systems-ltd)  [deltamembranesystems](https://www.youtube.com/deltamembranesystems)